



## DESCRIPTION

A24C512A provides 524288 bits of serial electrically erasable and programmable read-only memory (EEPROM), organized as 65536 bytes.

The A24C512A is optimized for use in many industrial and commercial applications where low-power and low-voltage operation is essential.

A24C512A offers an additional page, named the Identification Page (128 bytes). The Identification Page can be used to store sensitive application parameters which can be (later) permanently locked in Read-only mode.

The A24C512A is available in SOP8, TSSOP8 and DFN8 packages.

AEC-Q100 Qualified is available in SOP8, TSSOP8 DFN8 and SOT-25 packages.

## ORDERING INFORMATION

Package Type	Part Number	
SOP8 AEC-Q100 SPQ: 2,500pcs/Reel	M8	A24C512AM8VR-X
TSSOP8 AEC-Q100 SPQ: 3,000pcs/Reel	TMX8	A24C512ATMX8VR-X
DFN8 AEC-Q100 SPQ: 3,000pcs/Reel	J8	A24C512AJ8VR-X
SOT-25 AEC-Q100 SPQ: 3,000pcs/Reel	E5	A24C512AE5VR-X
Note	X: Temperature, AEC-Q B : -40°C to +105°C C : -40°C to +125°C Q : AEC-Q100 V: Halogen Free Package R: Tape & Reel	
AiT provides all RoHS products		

## FEATURES

- Compatible with all I<sup>2</sup>C bidirectional data transfer protocol
- Memory Array:  
512 Kbits (65536x8) of EEPROM  
Page size: 128 bytes  
Additional Write lockable page
- Extended Temperature Range  
B : -40°C to +105°C  
C : -40°C to +125°C  
Q : -40°C to +125°C (AEC-Q100 Certificated)
- Single Supply Voltage and High Speed:  
1MHz  
Random and sequential Read modes
- Write:  
Byte Write within 3 ms  
Page Write within 3 ms  
Partial Page Writes Allowed
- Write Protect Pin for Hardware Data Protection
- Schmitt Trigger, Filtered Inputs for Noise Suppression
- High-Reliability  
Endurance: 4 Million Write Cycles  
Data Retention: 100 Years
- Enhanced ESD/Latch-up Protection  
HBM 8000V



**PIN DESCRIPTION**

<p style="text-align: center;"><b>A24C512A</b> SOP8</p> <p style="text-align: center;">SOP8, M8 Top View</p>		<p style="text-align: center;"><b>A24C512A</b> TSSOP8</p> <p style="text-align: center;">TSSOP8, TMX8 Top View</p>		
<p style="text-align: center;"><b>A24C512A</b> DFN8</p> <p style="text-align: center;">DFN8, J8 Top View</p>		<p style="text-align: center;"><b>A24C512A</b> SOT-25</p> <p style="text-align: center;">SOT-25, E5 Top View</p>		
Pin #		Symbol	Type	Functions
SOP8 / TSSOP8 DFN8	SOT-25			
1,2,3	-	A0-A2	I	Address Inputs
4	2	GND	P	Ground
5	3	SDA	I/O	Serial Data
6	1	SCL	I	Serial Clock Input
7	5	WP	I	Write Protect
8	4	Vcc	P	Power Supply



## ABSOLUTE MAXIMUM RATINGS

DC Supply Voltage	-0.3V ~ +6.5V
Input / Output Voltage	GND-0.3V ~ V <sub>CC</sub> +0.3V
Storage Temperature	-65°C ~ +150°C
Electrostatic Pulse (Human Body Model)	8000V
Junction Temperature (T <sub>jmax</sub> )	150°C

Stresses above may cause permanent damage to the device. These are stress ratings only, and functional operation of the device at these or any other conditions beyond those indicated in the Electrical Characteristics is not implied. Exposure to absolute maximum rating conditions for extended periods may affect device reliability.

## PIN CAPACITANCE

Applicable over recommended operating range from: T<sub>A</sub> = 25°C, f = 400kHz, V<sub>CC</sub> = +1.7V

Parameter	Symbol	Condition	Min.	Typ.	Max.	Unit
Input/ Output Capacitance (SDA)	C <sub>I/O</sub>	V <sub>I/O</sub> =0V	-	-	8	pF
Input Capacitance (A0, A1, A2, SCL)	C <sub>IN</sub>	V <sub>IN</sub> =0V	-	-	6	pF

## DC ELECTRICAL CHARACTERISTICS

Applicable over recommended operating range, unless otherwise noted

A24C512A-B	T <sub>A</sub> = -40°C to +105°C	V <sub>CC</sub> = +1.7V to +5.5V@400kHz V <sub>CC</sub> = +2.5V to +5.5V@1MHz C <sub>L</sub> = 100 pF
A24C512A-C	T <sub>A</sub> = -40°C to +125°C	
A24C512A-Q	T <sub>A</sub> = -40°C to +125°C	

Parameter	Symbol	Condition	Min.	Typ.	Max.	Unit
Supply Current V <sub>CC</sub> = 5.0V	I <sub>CCR</sub>	Read at 400kHz	-	0.14	0.3	mA
Supply Current V <sub>CC</sub> = 5.0V	I <sub>CCW</sub>	Write at 400kHz	-	0.28	0.5	mA
Supply Current V <sub>CC</sub> = 5.0V	I <sub>SB</sub>	V <sub>IN</sub> = V <sub>CC</sub> or V <sub>SS</sub>	-	0.03	2.0	μA
Input Leakage Current	I <sub>LI</sub>	V <sub>IN</sub> = V <sub>CC</sub> or V <sub>SS</sub>	-	0.10	1.0	μA
Output Leakage Current	I <sub>LO</sub>	V <sub>OUT</sub> = V <sub>CC</sub> or V <sub>SS</sub>	-	0.05	1.0	μA
Input Low Level	V <sub>IL</sub>	V <sub>CC</sub> = 1.7V to 5.5V	-0.3	-	V <sub>CC</sub> x 0.3	V
Input High Level	V <sub>IH</sub>	V <sub>CC</sub> = 1.7V to 5.5V	V <sub>CC</sub> x 0.7	-	V <sub>CC</sub> + 0.3	V
Output Low Level V <sub>CC</sub> = 1.7V	V <sub>OL1</sub>	I <sub>OL</sub> = 0.15mA	-	-	0.2	V
Output Low Level V <sub>CC</sub> = 5.0V	V <sub>OL2</sub>	I <sub>OL</sub> = 3.0mA	-	-	0.4	V



## AC ELECTRICAL CHARACTERISTICS <sup>(2)</sup>

Applicable over recommended operating range, unless otherwise noted

A24C512A-B	T <sub>A</sub> = -40°C to +105°C	V <sub>CC</sub> = +1.7V to +5.5V@400kHz
A24C512A-C	T <sub>A</sub> = -40°C to +125°C	
A24C512A-Q	T <sub>A</sub> = -40°C to +125°C	V <sub>CC</sub> = +2.5V to +5.5V@1MHz
		C <sub>L</sub> = 100 pF

Parameter	Symbol	1.7V ≤ V <sub>CC</sub> < 2.5V			2.5V ≤ V <sub>CC</sub> < 5.5V			Unit
		Min.	Typ.	Max.	Min.	Typ.	Max.	
Clock Frequency, SCL	f <sub>SCL</sub>	-	-	400	-	-	1000	kHz
Clock Pulse Width Low	t <sub>LOW</sub>	1.3	-	-	0.5	-	-	μs
Clock Pulse Width High	t <sub>HIGH</sub>	0.6	-	-	0.26	-	-	μs
Noise Suppression Time	t <sub>i</sub>	-	-	50	-	-	50	ns
Clock Low to Data Out Valid	t <sub>AA</sub>	-	-	0.9	-	-	0.45	μs
Time the bus must be free before a new transmission can start	t <sub>BUF</sub>	1.3	-	-	0.5	-	-	μs
Start Hold Time	t <sub>HD,STA</sub>	0.6	-	-	0.25	-	-	μs
Start Setup Time	t <sub>SU,STA</sub>	0.6	-	-	0.25	-	-	μs
Data In Hold Time	t <sub>HD,DAT</sub>	0	-	-	0	-	-	μs
Data In Setup Time	t <sub>SU,DAT</sub>	100	-	-	100	-	-	ns
Inputs Rise Time <sup>(1)</sup>	t <sub>R</sub>	-	-	0.3	-	-	0.12	μs
Inputs Fall Time <sup>(1)</sup>	t <sub>F</sub>	-	-	0.3	-	-	0.12	μs
Stop Setup Time	t <sub>SU,STO</sub>	0.6	-	-	0.25	-	-	μs
Data Out Hold Time	t <sub>DH</sub>	50	-	-	50	-	-	ns
Write Cycle Time	t <sub>WR</sub>	-	1.9	3	-	1.9	3	ms
5.0V, 25°C, Byte Mode <sup>(1)</sup>	Endurance	4M	-	-	4M	-	-	Write Cycles

(1): This parameter is characterized and is not 100% tested.

(2): AC measurement conditions: R<sub>L</sub>(connects to V<sub>CC</sub>): 1.3K

Input pulse voltages: 0.3 V<sub>CC</sub> to 0.7V<sub>CC</sub>

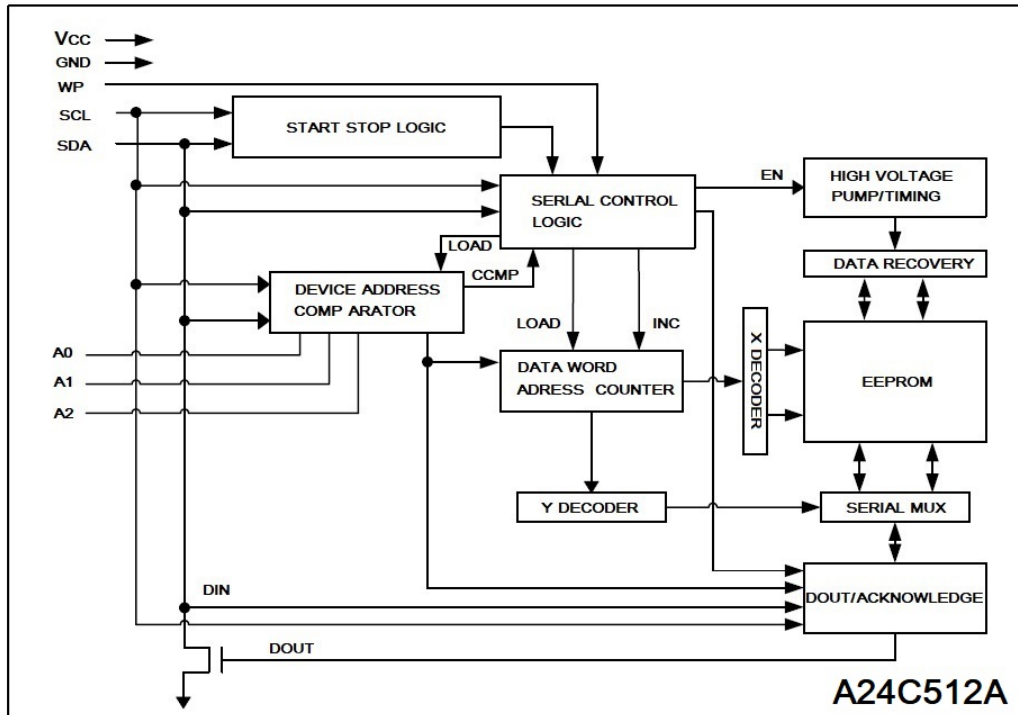
Input rise and fall time: 50ns

Input and output timing reference voltages: 0.5V<sub>CC</sub>

The value of R<sub>L</sub> should be concerned according to the actual loading on the user's system.



**BLOCK DIAGRAM**





## DETAILED INFORMATION

**DEVICE/PAGE ADDRESSES (A2, A1 and A0):** The A2, A1 and A0 pins are device address inputs that are hard wire for the A24C512A. Eight 32K devices may be addressed on a single bus system (device addressing is discussed in detail under the Device Addressing section).

**SERIAL DATA (SDA):** The SDA pin is bi-directional for serial data transfer. This pin is open-drain driven and may be wire-OR 'ed with any number of other open-drain or open- collector devices.

**SERIAL CLOCK (SCL):** The SCL input is used to positive edge clock data into each EEPROM device and negative edge clock data out of each device.

**WRITE PROTECT (WP):** The A24C512A has a Write Protect pin that provides hardware data protection. The Write Protect pin allows normal read/write operations when connected to ground (GND). When the Write Protection pin is connected to  $V_{CC}$ , the write protection feature is enabled and operates as shown in the following Table 1.

Table1: Write Protect

WP Pin Status	A24C512A
At $V_{CC}$	Full (512K) Array
At GND	Normal Read/Write Operations



## FUNCTION DESCRIPTION

### 1. Memory Organization

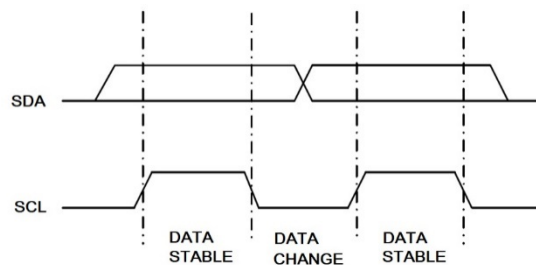
**A24C512A, 512K SERIAL EEPROM:** Internally organized with 512 pages of 128 bytes each, the 512K requires a 16-bit data word address for random word addressing.

### 2. Device Operation

#### CLOCK and DATA TRANSITIONS:

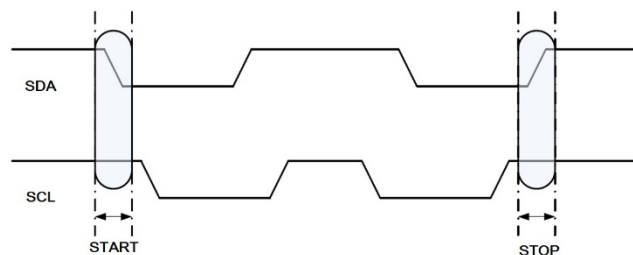
The SDA pin is normally pulled high with an external device. Data on the SDA pin may change only during SCL low time periods (see Figure 1). Data changes during SCL high periods will indicate a start or stop condition as defined.

Figure 1 Data Validity



**START CONDITION:** A high-to-low transition of SDA with SCL high is a start condition which must precede any other command (see Figure 2).

Figure 2 Start and Stop Definition

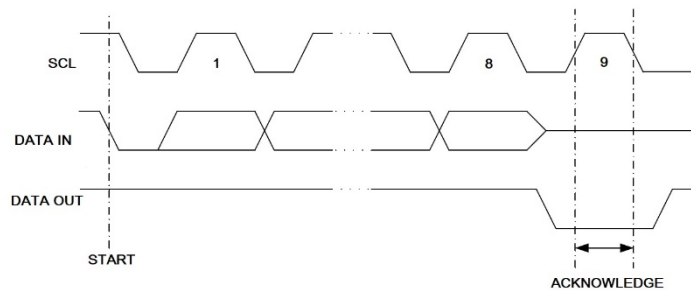


**STOP CONDITION:** A low-to-high transition of SDA with SCL high is a stop condition. (see Figure 2).

#### ACKNOWLEDGE:

All addresses and data words are serially transmitted to and from the EEPROM in 8-bit words. The EEPROM sends a "0" to acknowledge that it has received each word. This happens during the ninth clock cycle.

Figure 3 Output Acknowledge



**STANDBY MODE:** The A24C512A features a low-power standby mode which is enabled:

- (a) Upon power-up
- (b) After the receipt of the STOP bit and the completion of any internal operations.



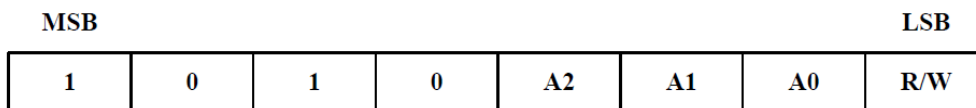
**MEMORY RESET:** After the protocol is interrupted, power loss or system reset, any two-wire part can be reset by following these steps:

1. Clock up to 9 cycles.
2. Look for SDA high in each cycle while SCL is high.
3. Create a start condition and a stop condition.

### 3. Device Addressing

The 512K EEPROM devices all require an 8-bit device address word following a start condition to enable the chip for a read or write operation (see Figure 4).

Figure 4 Device Address



The device address word consists of a mandatory "1", "0" sequence for the first four most significant bits as shown. This is common to all the Serial EEPROM devices.

The 512K EEPROM uses A2, A1 and A0 device address bits to allow as much as eight devices on the same bus. These 3 bits must be compared to their corresponding hardwired input pins. The A2, A1 and A0 pins use an internal proprietary circuit that biases them to a logic low condition if the pins are allowed to float.

The eighth bit of the device address is the read/write operation select bit. A read operation is initiated if this bit is high and a write operation is initiated if this bit is low.

Upon a compare of the device address, the EEPROM will output a "0". If a compare is not made, the chip will return to a standby state.

**DATA SECURITY:** The A24C512A has a hardware data protection scheme that allows the user to write protect the entire memory when the WP pin is at V<sub>CC</sub>.

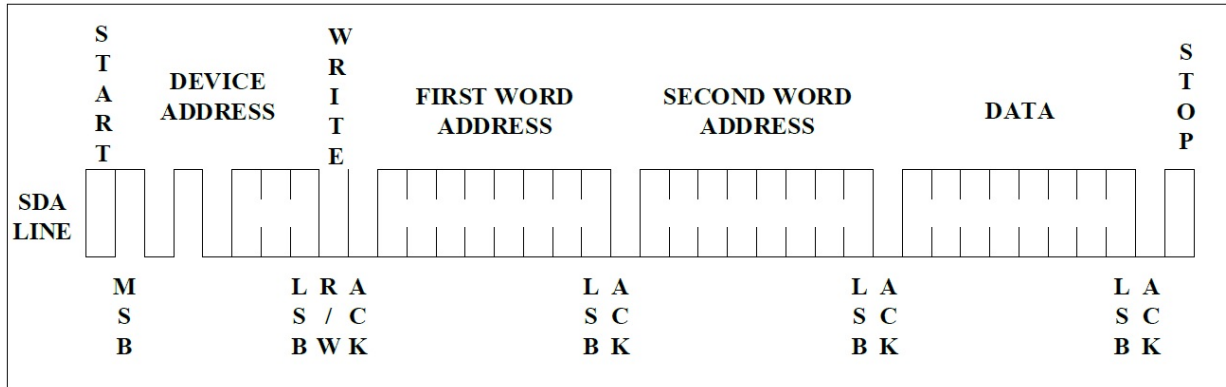
### 4. Write Operations

**BYTE WRITE:** A write operation requires an 8-bit data word address following the device address word and acknowledgment. Upon receipt of this address, the EEPROM will again respond with a "0" and then clock in the first 8-bit data word. Following receipt of the 8-bit data word, the EEPROM will output a "0" and the addressing device, such as a microcontroller, must terminate the write sequence with a stop condition. At this time the EEPROM enters an internally timed write cycle,  $t_{WR}$ , to the nonvolatile memory. All inputs are disabled during this write cycle and the EEPROM will not respond until the write is complete (see Figure 5).



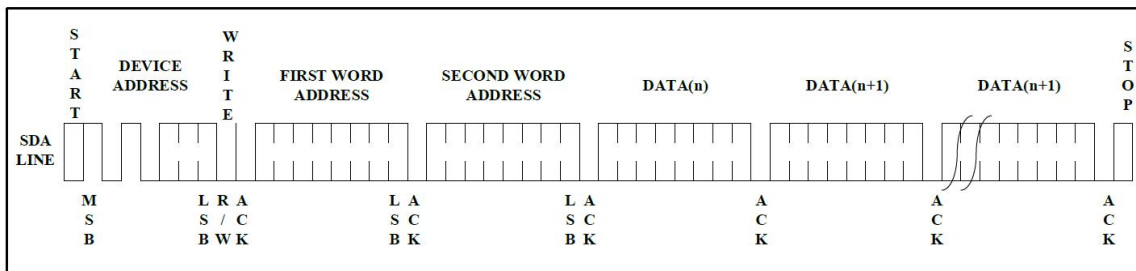


Figure 5 Byte Write



**PAGE WRITE:** The 512K EEPROM is capable of a 128-byte page writes. A page write is initiated the same as a byte writes, but the microcontroller does not send a stop condition after the first data word is clocked in. Instead, after the EEPROM acknowledges receipt of the first data word, the microcontroller can transmit up to 127 more data words. The EEPROM will respond with a "0" after each data word received. The microcontroller must terminate the page write sequence with a stop condition (see Figure 6).

Figure 6 Page Write



The data word address lower seven bits are internally incremented following the receipt of each data word. The higher data word address bits are not incremented, retaining the memory page row location. When the word address, internally generated, reaches the page boundary, the following byte is placed at the beginning of the same page. If more than 128 data words are transmitted to the EEPROM, the data word address will "roll over" and previous data will be overwritten.

**WRITE IDENTIFICATION PAGE:** The identification Page (128 bytes) is an additional page which can be written and (later) permanently locked in Read-only mode. It is written by issuing the Write Identification Page instruction. This instruction uses the same protocol and format as Page Write (into memory array), except for the following differences: Device type identifier = 1011b

MSB address bits B15/B7 are don't care except for address bit B10 which must be "0".

LSB address bits B6/B0 define the byte address inside the Identification page.

If the Identification page is locked, the data bytes transferred during the Write Identification Page instruction are not acknowledged (NoAck).



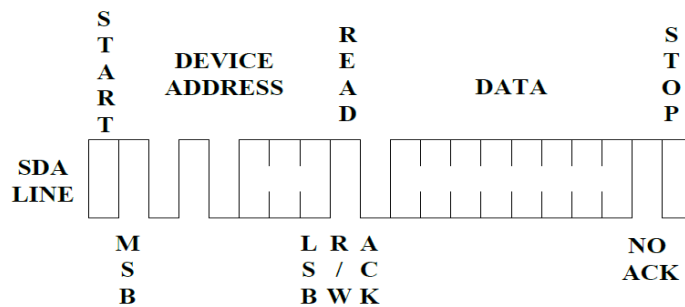
**ACKNOWLEDGE POLLING:** Once the internally timed write cycle has started and the EEPROM inputs are disabled, acknowledge polling can be initiated. This involves sending a start condition followed by the device address word. The read/write bit is representative of the operation desired. Only if the internal write cycle has completed will the EEPROM respond with a "0", allowing the read or write sequence to continue.

**5.Read Operations**

Read operations are initiated the same way as write operations with the exception that the read/write select bit in the device address word is set to "1". There are three read operations: current address read, random address read and sequential read.

**CURRENT ADDRESS READ:** The internal data word address counter maintains the last address accessed during the last read or write operation, incremented by one. This address stays valid between operations as long as the chip power is maintained. The address "roll over" during read is from the last byte of the last memory page to the first byte of the first page. The address "roll over" during write is from the last byte of the current page to the first byte of the same page. Once the device address with the read/write select bit set to "1" is clocked in and acknowledged by the EEPROM, the current address data word is serially clocked out. The microcontroller does not respond with an input "0" but does generate a following stop condition (see Figure 7).

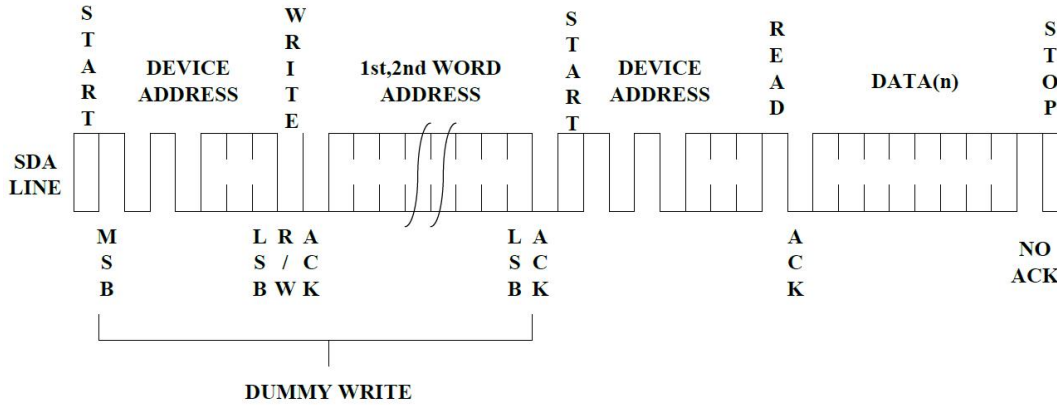
Figure 7 Current Address Read



**RANDOM READ:** A random read requires a "dummy" byte write sequence to load in the data word address. Once the device address word and data word address are clocked in and acknowledged by the EEPROM, the microcontroller must generate another start condition. The microcontroller now initiates a current address read by sending a device address with the read/write select bit high. The EEPROM acknowledges the device address and serially clocks out the data word. The microcontroller does not respond with a "0" but does generate a following stop condition (see Figure 8)

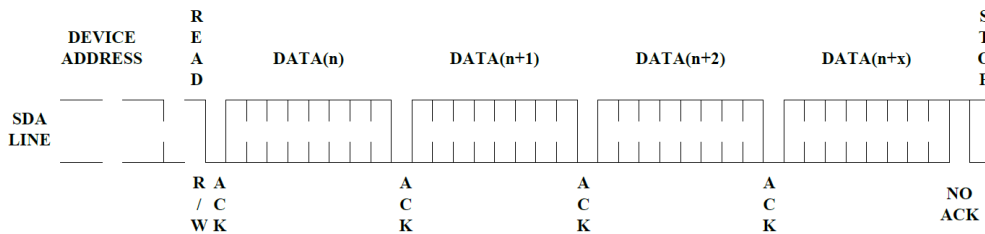


Figure 8 Random Read



**SEQUENTIAL READ:** Sequential reads are initiated by either a current address read or a random address read. After the microcontroller receives a data word, it responds with an acknowledge. As long as the EEPROM receives an acknowledge, it will continue to increment the data word address and serially clock out sequential data words. When the memory address limit is reached, the data word address will "roll over" and the sequential read will continue. The sequential read operation is terminated when the microcontroller does not respond with a "0" but does generate a following stop condition (see Figure 9).

Figure 9 Sequential Read



**READ IDENTIFICATION PAGE:** The Identification Page (128 bytes) is an additional page which can be written and (later) permanently locked in Read-only mode.

The Identification Page can be read by issuing a Read Identification Page instruction. This instruction uses the same protocol and format as the Random Address Read (from memory array) with device type identifier defined as 1011b. The MSB address bits B15/B7 are don't care, the LSB address bits B6/B0 define the byte address inside the Identification Page. The number of bytes to read in the ID page must not exceed the page boundary (e.g.: when reading the Identification Page from location 10d, the number of bytes should be less than or equal to 118, as the ID page boundary is 128 bytes)



**LOCK IDENTIFICATION PAGE:** The Lock Identification Page instruction (Lock ID) permanently locks the Identification page in Read-only mode. The Lock ID instruction is similar to Byte Write (into memory array) with the following specific conditions:

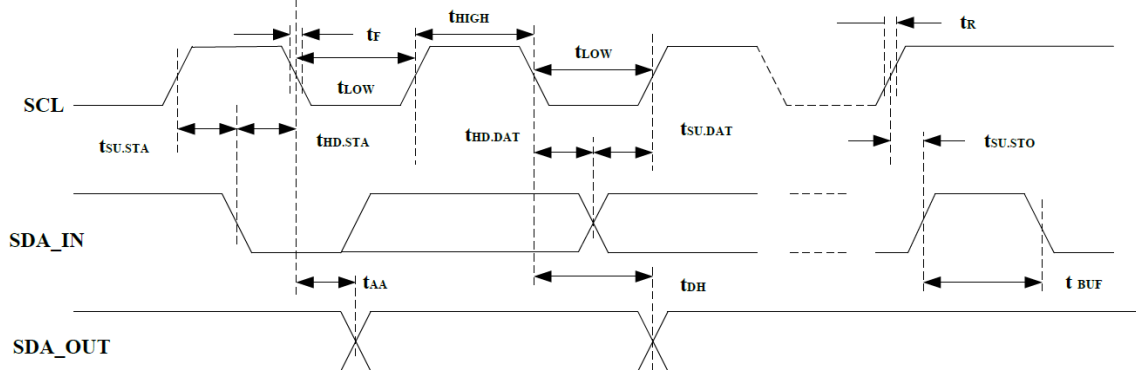
Device type identifier = 1011b

Address bit B10 must be "1"; all other address bits are don't care

The data byte must be equal to the binary value xxxx xx1x, where x is don't care

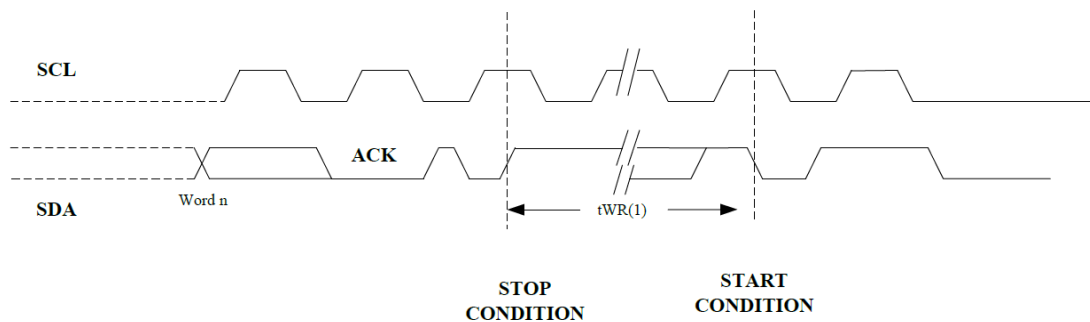
**BUS TIMING**

Figure 10 SCL: Serial Clock, SDA: Serial Data I/O



**WRITE CYCLE TIMING**

Figure 11 SCL: Serial Clock, SDA: Serial Data I/O

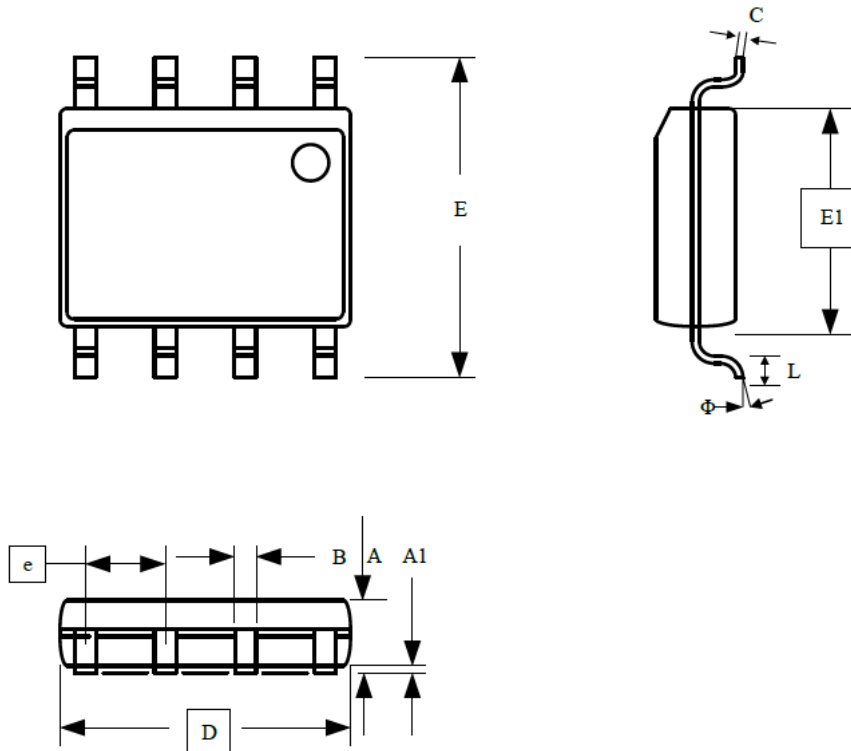


NOTE: The write cycle time  $t_{WR}$  is the time from a valid stop condition of a write sequence to the end of the internal clear/write cycle.



**PACKAGE INFORMATION**

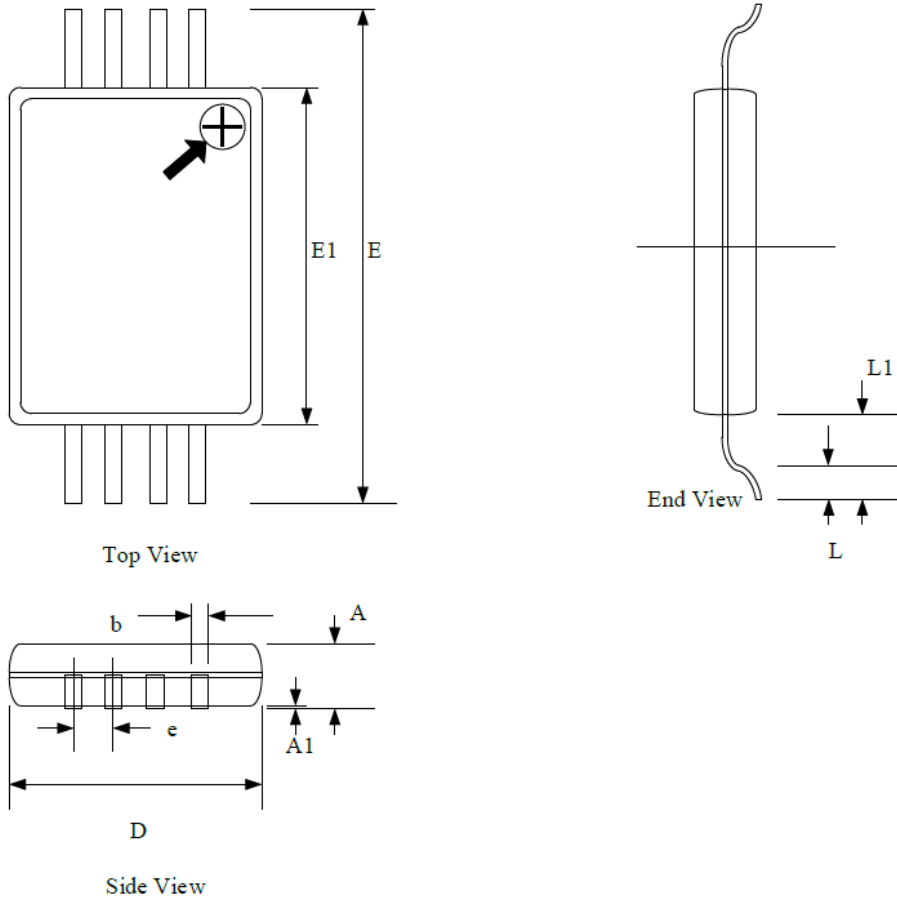
Dimension in SOP8 (Unit: mm)



Symbol	Min	Max
A	1.350	1.750
A1	0.100	0.230
B	0.390	0.480
C	0.210	0.260
D	4.700	5.100
E1	3.700	4.100
E	5.800	6.200
e	1.27BSC	
L	0.500	0.800
θ	0°	8°



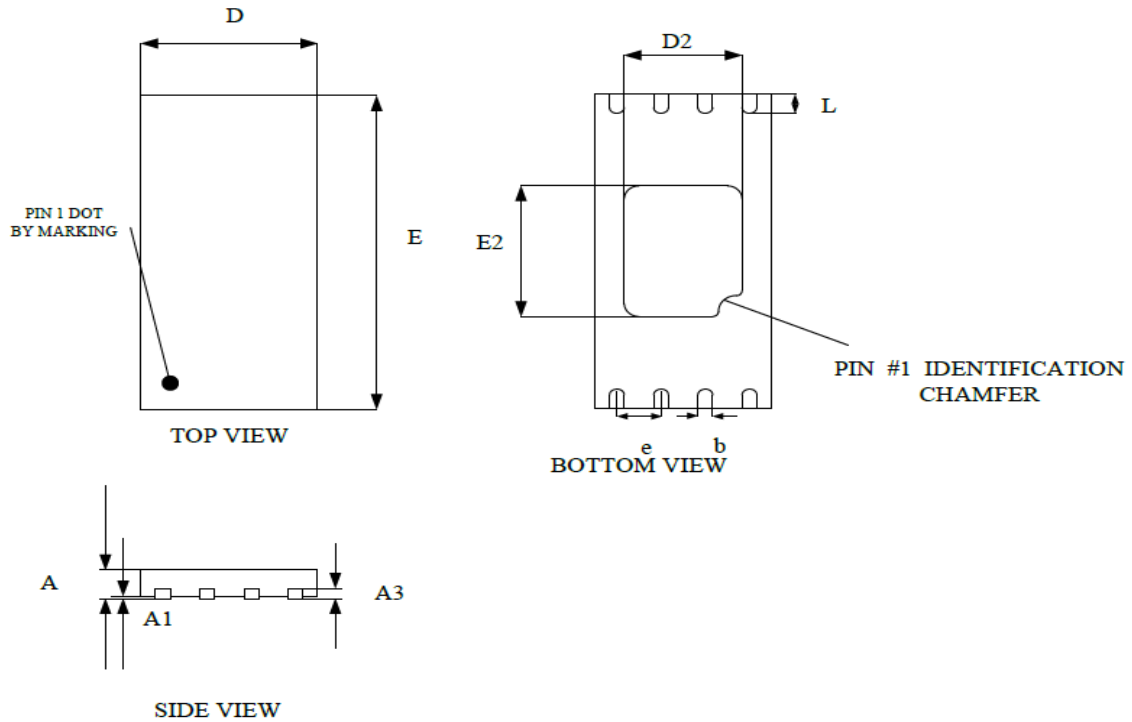
Dimension in TSSOP8 Package (Unit: mm)



Symbol	Min	Max
D	2.900	3.100
E	6.200	6.600
E1	4.300	4.500
A	-	1.200
A1	0.050	0.150
b	0.210	0.300
e	0.650 BSC	
L	0.450	0.750
L1	1.000 REF	



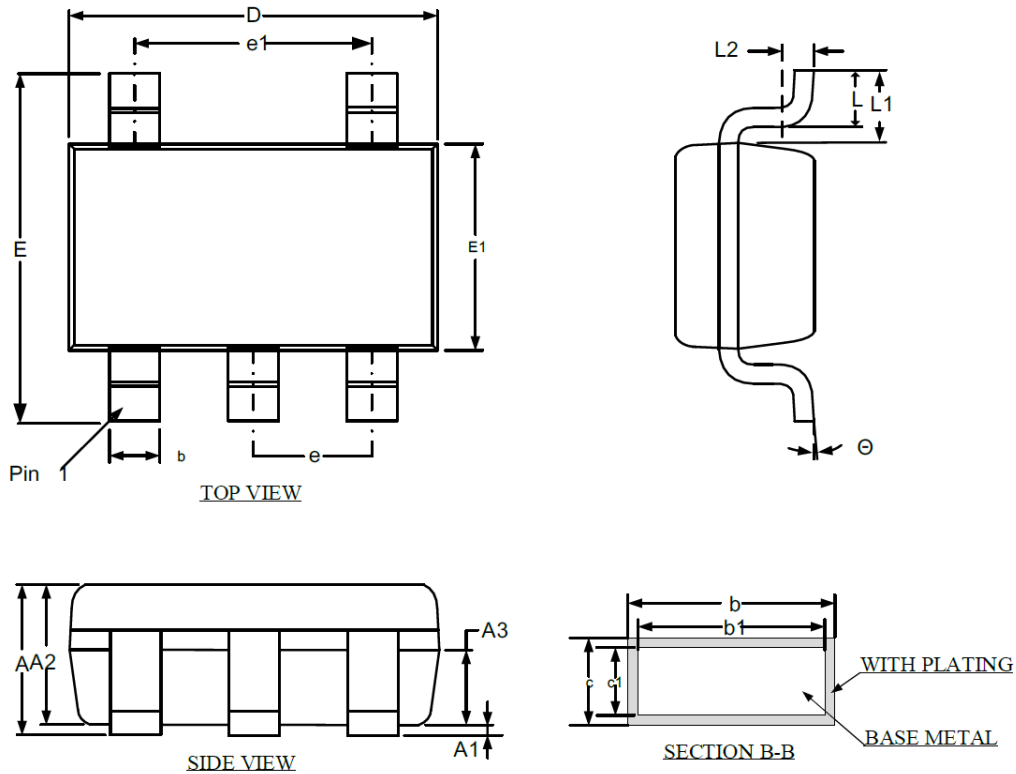
Dimension in DFN8 (Unit: mm)



Symbol	Min	Max
A	0.500	0.600
A1	0.000	0.050
A3	0.15 REF	
D	1.950	2.050
E	2.950	3.050
b	0.200	0.300
L	0.200	0.400
D2	1.250	1.500
E2	1.150	1.400
e	0.500 BSC	



Dimension in SOT-25 (Unit: mm)



Symbol	Min.	Max.
A	-	1.350
A1	0.040	0.150
A2	1.000	1.200
A3	0.550	0.750
b	0.380	0.480
b1	0.370	0.430
c	0.110	0.210
c1	0.100	0.160
D	2.720	3.120
E	2.600	3.000
E1	1.400	1.800
e	0.950 BSC	
e1	1.900 BSC	
L	0.300	0.600
L1	0.575 REF	
L2	0.258 BSC	
θ	0°	8°





## IMPORTANT NOTICE

AiT Semiconductor Inc. (AiT) reserves the right to make changes to any its product, specifications, to discontinue any integrated circuit product or service without notice, and advises its customers to obtain the latest version of relevant information to verify, before placing orders, that the information being relied on is current.

AiT Semiconductor Inc.'s integrated circuit products are not designed, intended, authorized, or warranted to be suitable for use in life support applications, devices or systems or other critical applications. Use of AiT products in such applications is understood to be fully at the risk of the customer. As used herein may involve potential risks of death, personal injury, or serve property, or environmental damage. In order to minimize risks associated with the customer's applications, the customer should provide adequate design and operating safeguards.

AiT Semiconductor Inc. assumes to no liability to customer product design or application support. AiT warrants the performance of its products of the specifications applicable at the time of sale.