



DESCRIPTION

A7642 is an asynchronous PWM boost converter using a constant frequency peak current mode. An external Schottky diode is needed.

At light load, A7642 works in the light load mode. The supply current during the light mode is 100uA , together with the 200mΩ internal NMOS power transistor guarantees high efficiency in the whole output load current range.

Up to 2A peak current, Let A7642 can provide 1A output load current, which is suitable to use as MID and mobile power supply. The input voltage 3V~12V. The operating frequency is internally set at 1MHz.

The A7642 is available in SOT-26 package.

ORDERING INFORMATION

Package Type	Part Number	
SOT-26	E6	A7642E6R
SPQ : 3,000pcs/Reel		A7642E6VR
Note	V: Halogen free Package R: Tape & Reel	
AiT provides all RoHS products		

FEATURES

- Wide input range: 3~12V, 20V_{OUT} max
- High Efficiency: Up to 92%
- 1.0MHz Constant Switching Frequency
- Switch current up to 2A
- Low R_{DS(ON)}: 0.2Ω
- Accurate Reference:0.6V
- Tiny External Components
- Available in SOT-26 package

APPLICATION

- WLED Drivers
- Networking cards powered from PCI or PCI-express slots
- MID and Mobile Power

TYPICAL APPLICATION

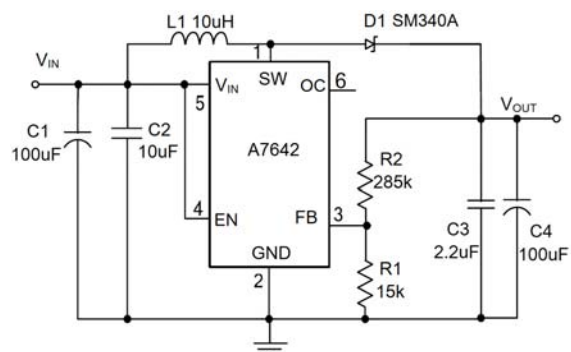
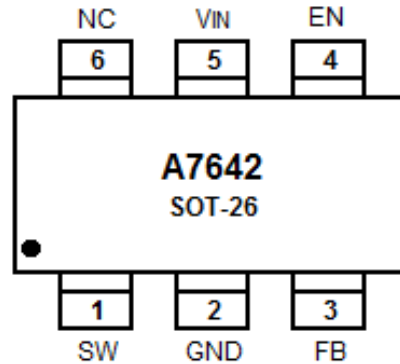

Figure 1: A7642 Typical Circuit
AiT Semi provide
A7642, D1:SM340A and L1: 10uH



PIN DESCRIPTION



Top View

Pin #	Symbol	Function
1	SW	Power Switch Pin. It is the switch node connection to Inductor.
2	GND	Ground Pin.
3	FB	Feedback Input Pin. Connect FB to the center point of the external resistor divider. The feedback threshold voltage is 0.6V.
4	EN	Chip Shutdown Signal Input. Logic high is normal operation mode, Logic Low is Shutdown. Don't leave it floated.
5	V _{IN}	Power Supply Input. Must be closely decoupled to GND, Pin 2, with a 10 μ F or greater ceramic capacitor.
6	NC	No Internal Connection.



ABSOLUTE MAXIMUM RATINGS

Input Supply Voltage	-0.3V~+16V
SW, SHDN Voltage	-0.3V~+24V
FB Voltages	-0.3V~+6V
Package Thermal Resistance ^{NOTE1}	
θ_{JA}	160°C/W
θ_{JC}	40°C/W
Operating Temperature Range	-40°C ~+85°C
Storage Temperature Range	-55°C~+150°C
Lead Temperature (Soldering, 10s)	+260°C

Stress beyond above listed "Absolute Maximum Ratings" may lead permanent damage to the device. These are stress ratings only and operations of the device at these or any other conditions beyond those indicated in the operational sections of the specifications are not implied. Exposure to absolute maximum rating conditions for extended periods may affect device reliability.

NOTE1: Thermal Resistance is specified with approximately 1 square of 1oz copper.

ELECTRICAL CHARACTERISTICS^{NOTE2}

$V_{OUT}=12V$, $T_A = 25^\circ C$, Test Circuit of Figure 1, unless otherwise noted.

Parameter	Symbol	Conditions	Min.	Typ.	Max.	Unit
Input Voltage Range	V_{IN}		3	-	12	V
Quiescent Current	I_Q	FB=0.66V, No switch	-	200	-	μA
Shutdown Current	I_{SHDN}	EN=0	-	-	1	μA
Low Side Main FET RON	$R_{DS(ON)}$		-	200	-	m Ω
Main FET Current Limit	I_{LIM1}		-	2	-	A
Switching Frequency	F_{SW}	$V_{IN}=5V, I_O=300mA$	0.8	1	1.2	MHz
Feedback Reference Voltage	V_{REF}	$V_{IN}=5V, I_O=10mA$	0.588	0.6	0.612	V
IN UVLO Rising Threshold	V_{UVLO}	V_{IN} Rising	-	-	2.7	V
UVLO Hysteresis	$UVLO_{.HYS}$		-	0.3	-	V
EN High Level Input Voltage	V_{ENH}		-	-	1.9	$^\circ C$
EN Low High Level Input Voltage	V_{ENL}		0.4	-	-	$^\circ C$
Thermal Shutdown Temperature	T_{SD}		-	150	-	$^\circ C$

NOTE2: 100% production test at +25°C. Specifications over the temperature range are guaranteed by design and characterization.



TYPICAL PERFORMANCE CHARACTERISTICS

$T_A=25^\circ\text{C}$, $V_{IN}=5\text{V}$, $V_{OUT}=12\text{V}$, unless otherwise specified.

1. Startup Waveforms

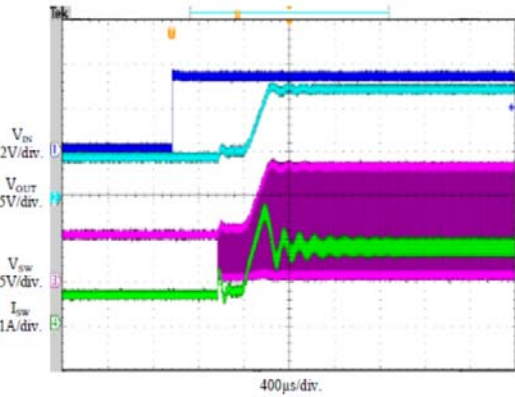

2. Shutdown Waveforms

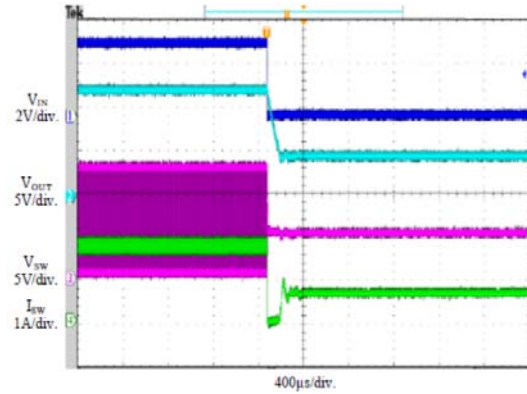

3. V_{OUT} vs Load Current

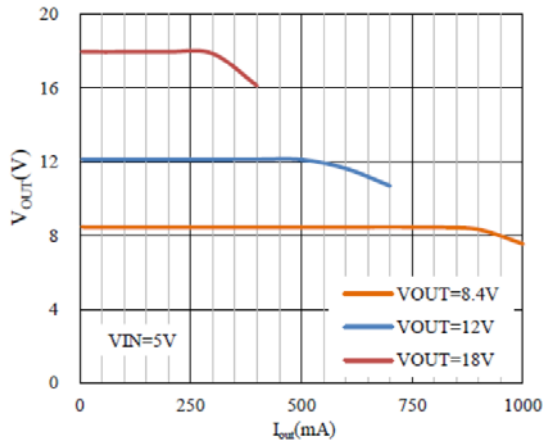

4. Current Limit vs Resistance

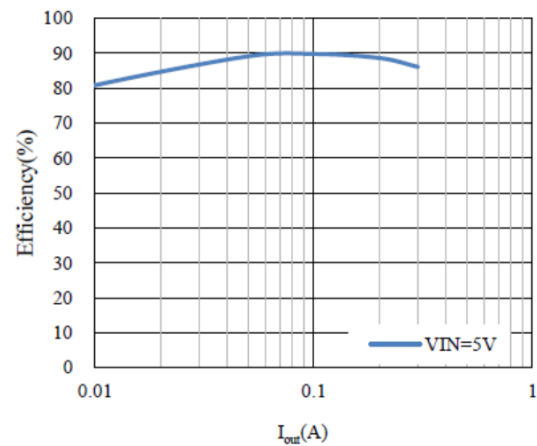

5. Efficiency vs Load Current, $V_{OUT}=8.4\text{V}$

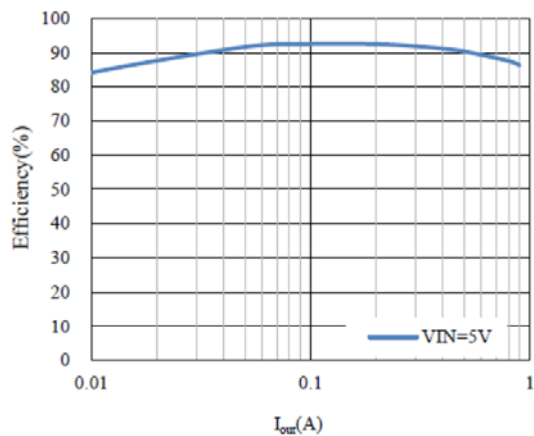

6. Efficiency vs Load Current, $V_{OUT}=18\text{V}$

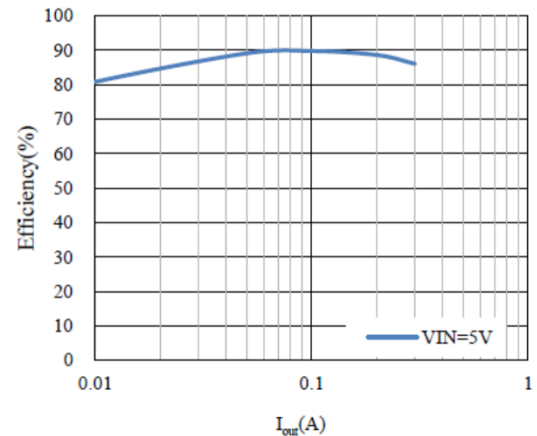



BLOCK DIAGRAM

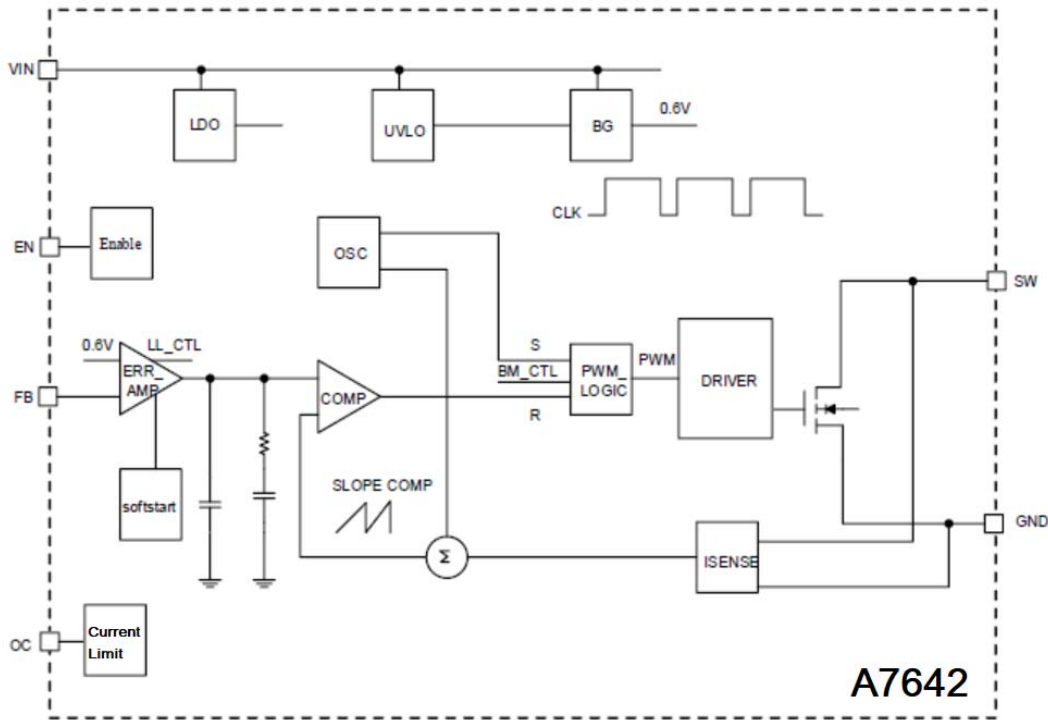



DETAILED INFORMATION

Operation

The A7642 uses a fixed frequency, peak current mode boost regulator architecture to regulate voltage at the feedback pin. The operation of the A7642 can be understood by referring to the block diagram of BLOCK DIAGRAM. At the start of each oscillator cycle the MOSFET is turned on through the control circuitry. To prevent subharmonic oscillations at duty cycles greater than 50 percent, a stabilizing ramp is added to the output of the current sense amplifier and the result is fed into the negative input of the PWM comparator. When this voltage equals the output voltage of the error amplifier the power MOSFET is turned off. The voltage at the output of the error amplifier is an amplified version of the difference between the 0.6V bandgap reference voltage and the feedback voltage. In this way the peak current level keeps the output in regulation. If the feedback voltage starts to drop, the output of the error amplifier increases. These results in more current to flow through the power MOSFET, thus increasing the power delivered to the output. The A7642 has internal soft start to limit the amount of input current at startup and to also limit the amount of overshoot on the output.

Adjustable Peak Current Limit

The peak current limit prevents the A7642 from high inductor current and from drawing excessive current from the input voltage rail. Excessive current might occur with a shorted/saturated inductor or a heavy load condition. If the inductor current reaches the peak limit threshold, the main switch is turned off and the external Schottky diode is turned on to ramp down the inductor current. The peak current limit is programmable through the external resistor 'R3' connected between the OC pin and ground.

For a current limit of 1.8 A, the resistor should be set at 30 kΩ. The minimum of the peak current limit must be higher than the required peak switch current at the lowest input voltage and highest output power to ensure the peak switch current will not be hit under normal operation. #4. of Typical Performance Characteristics shows the relationship between the Current Limit and the Setting Resistance.

Application Information

Setting the Output Voltage

The internal reference V_{REF} is 0.6V (Typical). The output voltage is divided by a resistor divider, R1 and R2 to the FB pin. The output voltage is given by

$$V_{OUT} = 0.6V \times \left(1 + \frac{R2}{R1}\right)$$



Inductor Selection

The recommended values of inductor is 10 μ H. Small size and better efficiency are the major concerns for portable device. The inductor should have low core loss at 1.0 MHz and low DCR for better efficiency. To avoid inductor saturation current rating should be considered.

Capacitor Selection

Input ceramic capacitor of 10 μ F is recommended for A7642 applications. For better voltage filtering, ceramic capacitors with low ESR are recommended. X5R and X7R types are suitable because of their wider voltage and temperature ranges.

Diode Selection

Schottky diode SM140A, provided by AiT Semi, is a good choice for A7642 because of its low forward voltage drop and fast reverses recovery. Using Schottky diode can get better efficiency. The high speed rectification is also a good characteristic of Schottky diode for high switching frequency. The average current rating must be greater than the 1.5 times value of maximum load current expected, and the peak current rating must be greater than the peak inductor current. The diode's reverse breakdown voltage should be larger than the 1.25 times value of output voltage.

Layout Consideration

For best performance of the A7642, the following guidelines must be strictly followed.

- Input and Output capacitors should be placed close to the IC and connected to ground plane to reduce noise coupling.
- The GND should be connected to a strong ground plane for heat sinking and noise protection.
- Keep the main current traces as possible as short and wide.
- SW node of DC-DC converter is with high frequency voltage swing. It should be kept at a small area.
- Place the feedback components as close as possible to the IC and keep away from the noisy device



PACKAGE INFORMATION

Dimension in SOT-26 Package (Unit: mm)

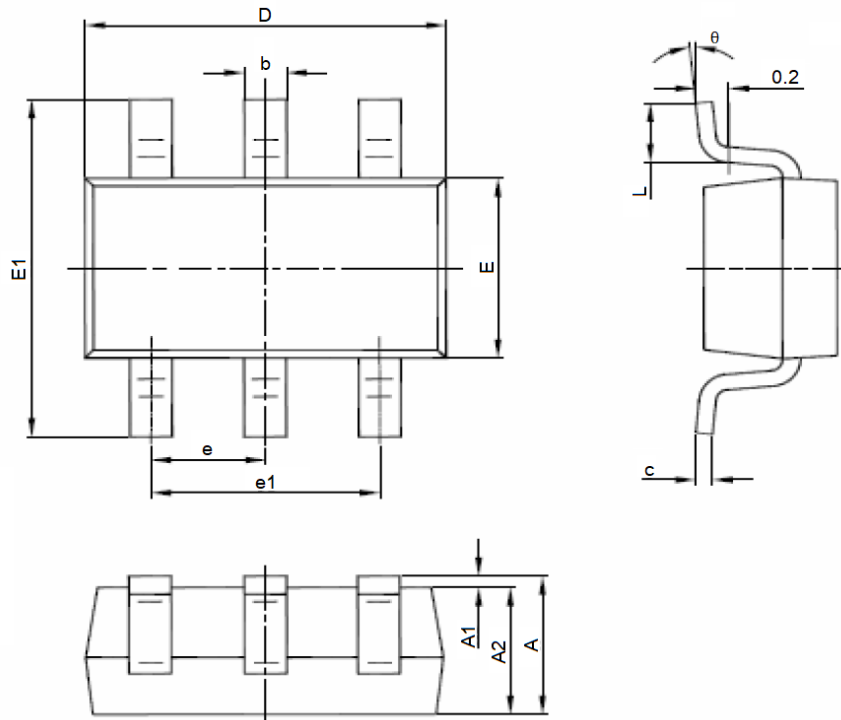

Symbol	Millimeters		Inches	
	Min	Max	Min	Max
A	1.050	1.250	0.041	0.049
A1	0.000	0.100	0.000	0.004
A2	1.050	1.150	0.041	0.045
b	0.300	0.500	0.012	0.020
c	0.100	0.200	0.004	0.008
D	2.820	3.020	0.111	0.119
E	1.500	1.700	0.059	0.067
E1	2.650	2.950	0.104	0.116
e	0.950 BSC		0.037 BSC	
e1	1.800	2.000	0.071	0.079
L	0.300	0.600	0.012	0.024
theta	0°	8°	0°	8°



IMPORTANT NOTICE

AiT Semiconductor Inc. (AiT) reserves the right to make changes to any its product, specifications, to discontinue any integrated circuit product or service without notice, and advises its customers to obtain the latest version of relevant information to verify, before placing orders, that the information being relied on is current.

AiT Semiconductor Inc.'s integrated circuit products are not designed, intended, authorized, or warranted to be suitable for use in life support applications, devices or systems or other critical applications. Use of AiT products in such applications is understood to be fully at the risk of the customer. As used herein may involve potential risks of death, personal injury, or severe property, or environmental damage. In order to minimize risks associated with the customer's applications, the customer should provide adequate design and operating safeguards.

AiT Semiconductor Inc. assumes to no liability to customer product design or application support. AiT warrants the performance of its products of the specifications applicable at the time of sale.