



DESCRIPTION

The AM8958 is the N & P-Channel enhancement mode power field effect transistor using high cell density DMOS trench technology. This high density process is especially tailored to minimize on-state resistance and provide superior switching performance. This device is particularly suited for low voltage application such as notebook computer power management and other battery powered circuits, where high-side switching, low inline power loss and resistance to transient are needed.

The AM8958 is available in SOP8 Package

ORDERING INFORMATION

Package Type	Part Number	
SOP-8	M8	AM8958M8R
		AM8958M8VR
Note	R: Tape & Reel V: Green Package	
AiT provides all Pb free products Suffix " V " means Green Package		

FEATURES

N-Channel

- 30V / 6.8A, $R_{DS(ON)} = 23m\Omega$ (typ.)@ $V_{GS} = 10V$
- 30V / 6.5A, $R_{DS(ON)} = 34m\Omega$ (typ.)@ $V_{GS} = 4.5V$

P-Channel

- -30V / -6.5A, $R_{DS(ON)} = 35m\Omega$ (typ.)@ $V_{GS} = -10V$
- -30V / -4.4A, $R_{DS(ON)} = 60m\Omega$ (typ.)@ $V_{GS} = -4.5V$
- Super high density cell design for extremely low $R_{DS(ON)}$
- Exceptional on-resistance and Maximum DC current capability
- Available in SOP8 Package

APPLICATION

- Power Management in Note book
- Portable Equipment
- Battery Powered System

P-CHANNEL MOSFET

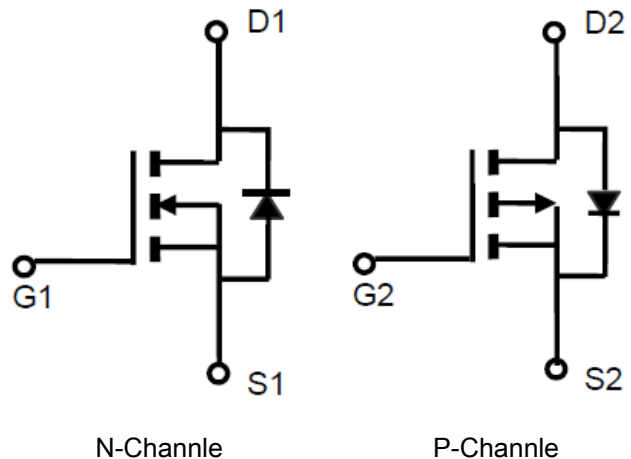



PIN DESCRIPTION

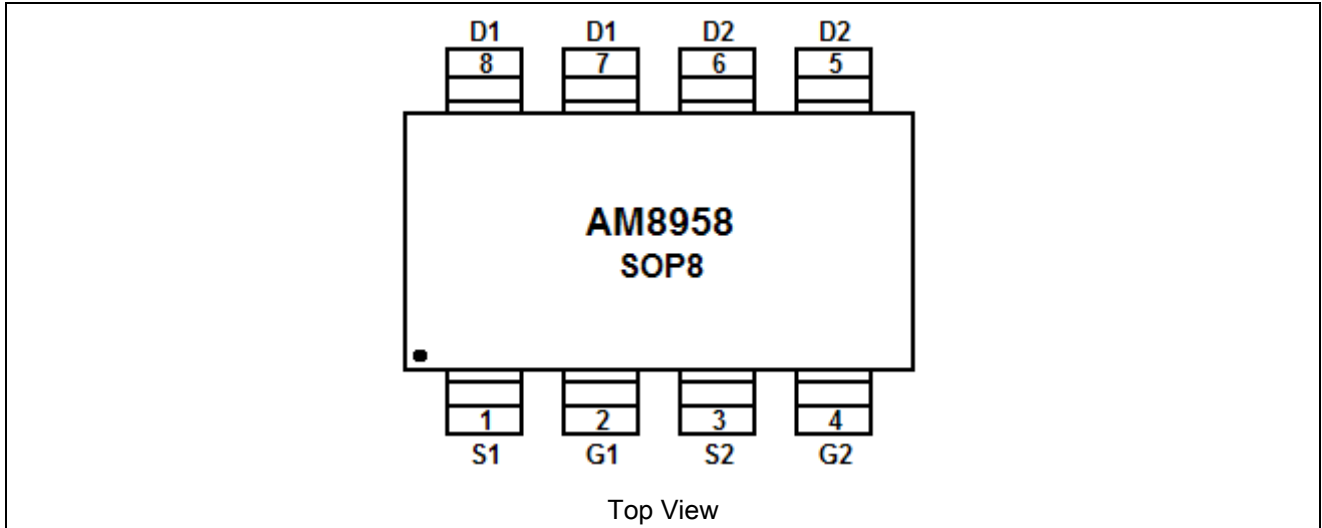

Pin #	Symbol	Function
1	S1	Source1
2	G1	Gate1
3	S2	Source2
4	G2	Gate2
5	D2	Drain2
6	D2	Drain2
7	D1	Drain1
8	D1	Drain1



ABSOLUTE MAXIMUM RATINGS

T_A = 25°C Unless otherwise specified

Symbol	Parameter	Typical		Unit
		N	P	
V _{DSS}	Drain-Source Voltage	30	-30	V
V _{GSS}	Gate-Source Voltage	±20	±20	V
I _D	Continuous Drain Current (T _J =150°C)	T _A =25°C		A
I _{DM}	Pulsed Drain Current	25	-25	A
I _S	Continuous Source Current (Diode Conduction)	2.3	-2.3	A
P _D	Power Dissipation			
	T _A =25°C	2.5	2.8	W
	T _A =70°C	1.6	1.8	W
T _J	Operation Junction Temperature	150		°C
T _{STG}	Storage Temperature Range	-55~150		°C

Stresses above may cause permanent damage to the device. These are stress ratings only and functional operation of the device at these or any other conditions beyond those indicated in the Electrical Characteristics are not implied. Exposure to absolute maximum rating conditions for extended periods may affect device reliability.

THERMAL INFORMATION

Parameter	Symbol	Min	Typ	Max	Unit
Thermal Resistance-Junction to Ambient	R _{θJA}	50	-	80	°C/W



ELECTRICAL CHARACTERISTICS

T_A = 25°C Unless otherwise specified

Parameter	Symbol	Conditions	Min	Typ	Max	Unit	
Drain-Source Breakdown Voltage	V _{(BR)DSS}	V _{GS} =0V, I _D =250μA	N	30	-	-	V
		V _{GS} =0V, I _D =-250μA	P	-30	-	-	
Gate Threshold Voltage	V _{GS(th)}	V _{DS} =V _{GS} , I _D =250μA	N	1.0	-	-2.5	V
			P	-1.0	-	-2.5	
Gate Leakage Current	I _{GSS}	V _{DS} =0V, V _{GS} =±20V	N	-	-	±100	nA
			P	-	-	±100	
Zero Gate Voltage Drain Current	I _{DSS}	V _{DS} =24V, V _{GS} =0V	N	-	-	1	μA
		V _{DS} =-24V, V _{GS} =0V	P	-	-	-1	
		V _{DS} =24V, V _{GS} =0V T _J =80°C	N	-	-	30	
		V _{DS} =-24V, V _{GS} =0V T _J =80°C	P	-	-	-30	
On-State Drain Current	I _{D(ON)}	V _{DS} ≥5V, V _{GS} =10V	N	30	-	-	A
		V _{DS} ≤-5V, V _{GS} =-10V	P	-30	-	-	
Drain-source On-Resistance	R _{DS(ON)}	V _{GS} =10V, I _D =6.8A	N	-	23	30	mΩ
		V _{GS} =-10V, I _D =-6.5A	P	-	35	50	
		V _{GS} =4.5V, I _D =6.5A	N	-	34	42	
		V _{GS} =-4.5V, I _D =-5A	P	-	60	85	
Source-Drain Diode							
Diode Forward Voltage	V _{SD}	I _S =1.7A, V _{GS} =0V	N	-	0.7	1.2	V
		I _S =-1.7A, V _{GS} =0V	P	-	-0.7	-1.2	
Dynamic Parameters							
Total Gate Charge	Q _g	N-Channel V _{DS} =15V, V _{GS} =10V	N	-	13	20	nC
			P	-	15	25	
Gate-Source Charge	Q _{GS}	I _D =6.0A P-Channel	N	-	2.3	-	
			P	-	4.0	-	
Gate-Drain Charge	Q _{GD}	V _{DS} =-15V, V _{GS} =-10V I _D =-5.0A	N	-	2.0	-	
			P	-	2.0	-	
Turn-On Time	t _{d(on)}	N-Channel V _{DD} =15V, R _L =150Ω	N	-	6.0	12	nS
			P	-	7.0	15	
	T _r	I _D =1.0A, V _{GEN} =10V R _G =6Ω	N	-	14	25	
			P	-	10	20	
Turn-Off Time	t _{d(off)}	P-Channel V _{DD} =-15V, R _L =150Ω	N	-	30	60	
			P	-	40	80	
	T _f	I _D =-1.0A, V _{GEN} =-10V R _G =6Ω	N	-	5	10	
			P	-	20	40	

NOTE: 1. Pulse test: pulse width ≤ 300us, duty cycle ≤ 2%

2. Static parameters are based on package level with recommended wire-bonding



TYPICAL CHARACTERISTICS

N-Channel

1. Output Characteristics

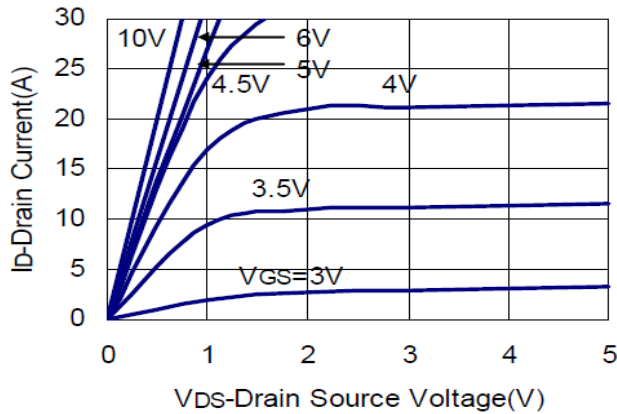

2. Drain Source On Resistance

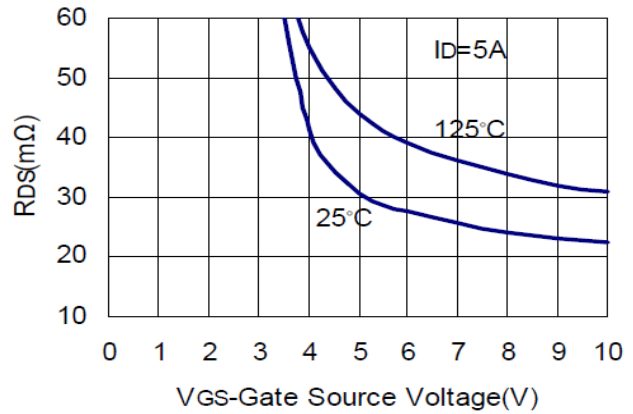

3. Drain Source On Resistance

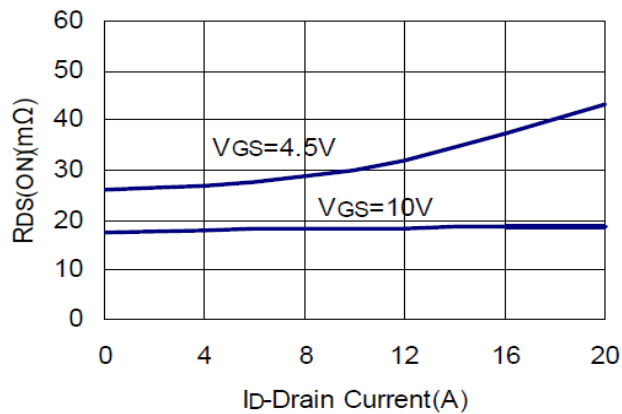

4. Gate Threshold Voltage

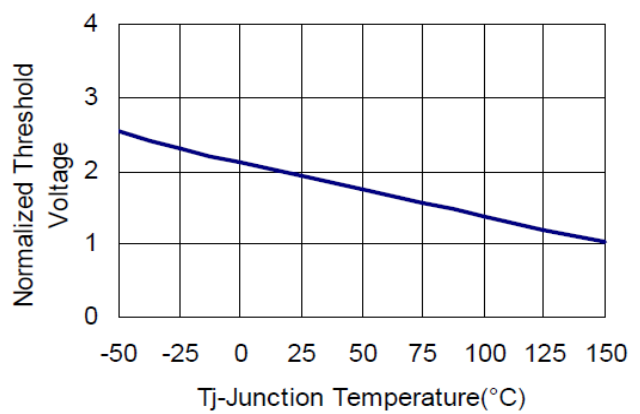

5. Gate Charge

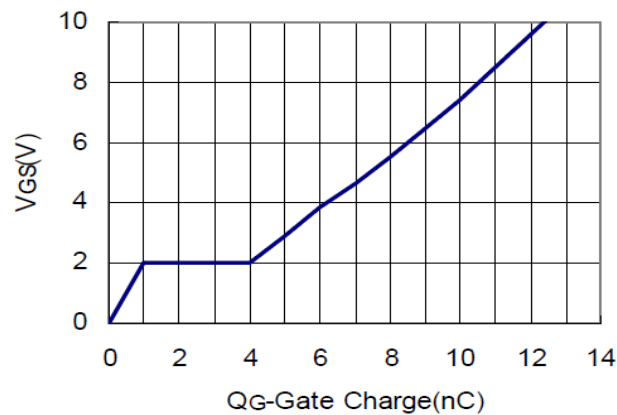

6. Drain Source On Resistance

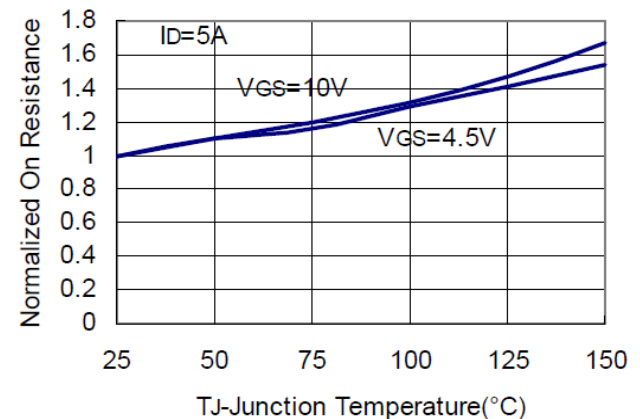



7. Source Drain Diode Forward

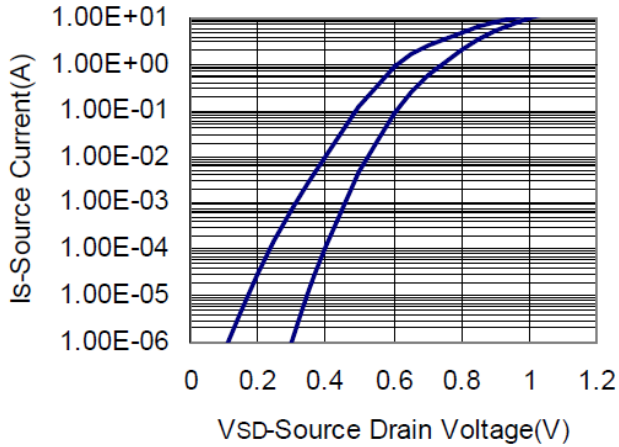

8. Capacitance

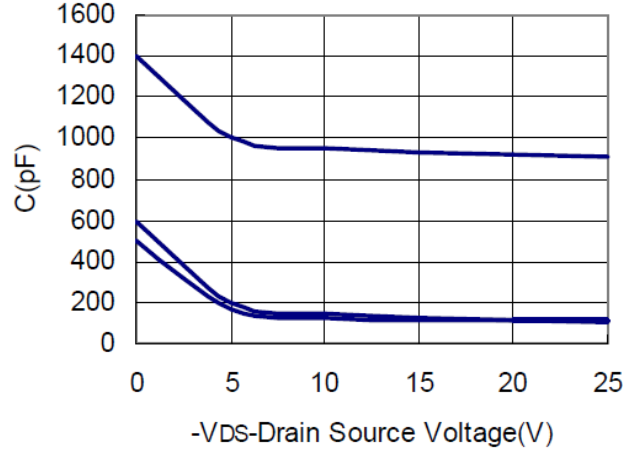

9. Power Dissipation

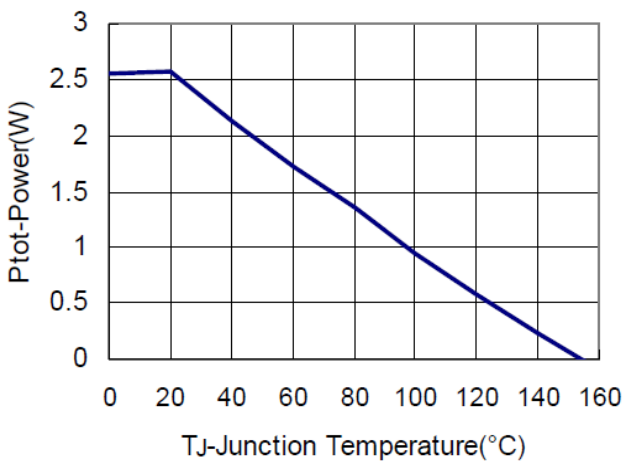

10. Drain Current

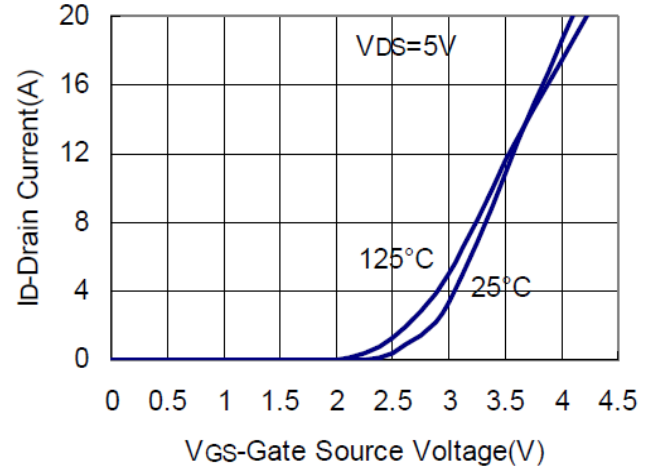

11. Thermal Transient Impedance

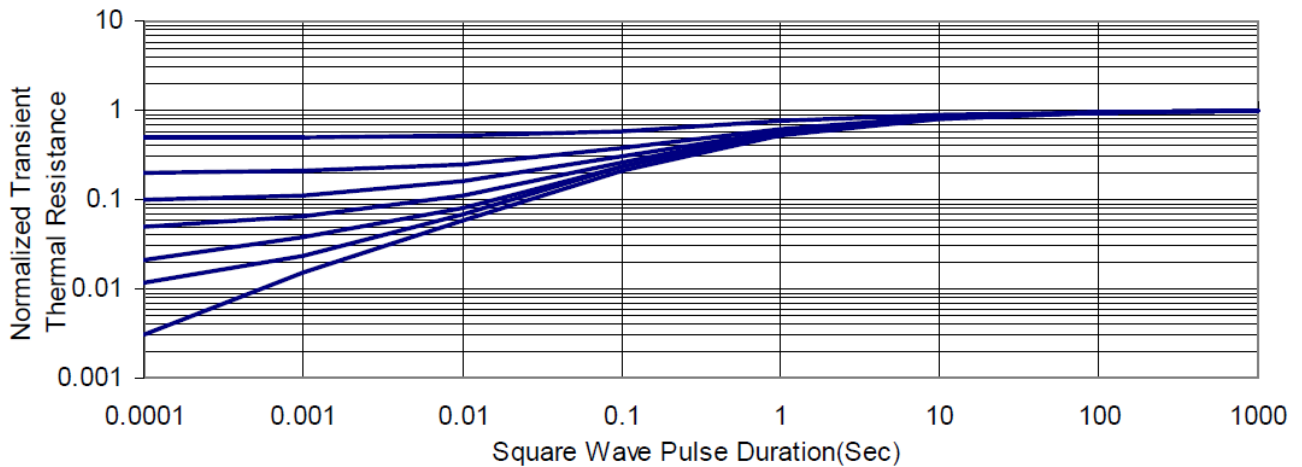



P-Channel

12. Output Characteristics

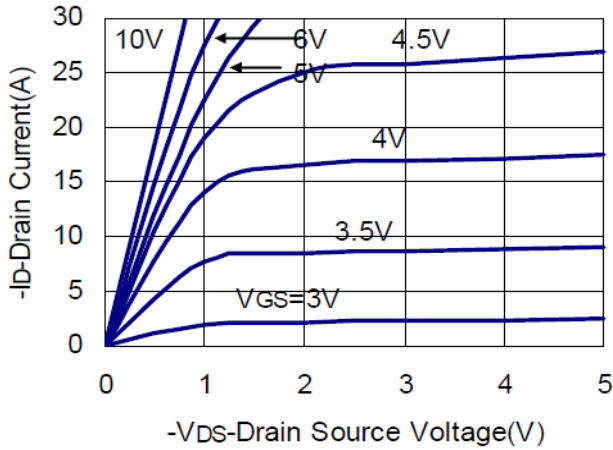

13. Drain Source On Resistance

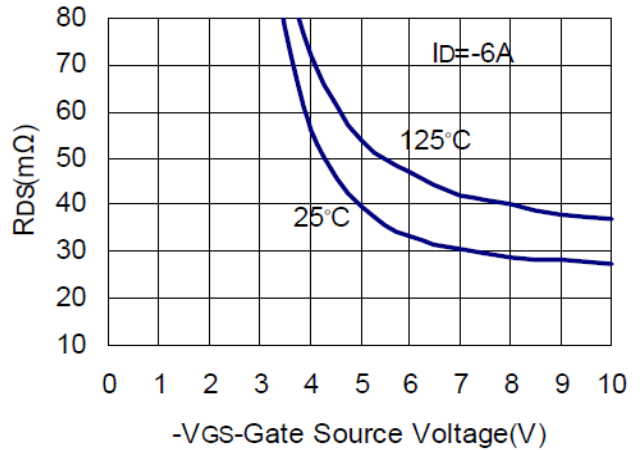

14. Drain Source On Resistance

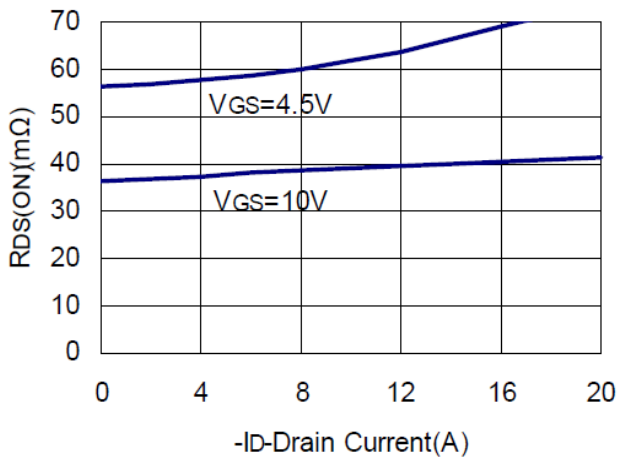

15. Gate Threshold Voltage

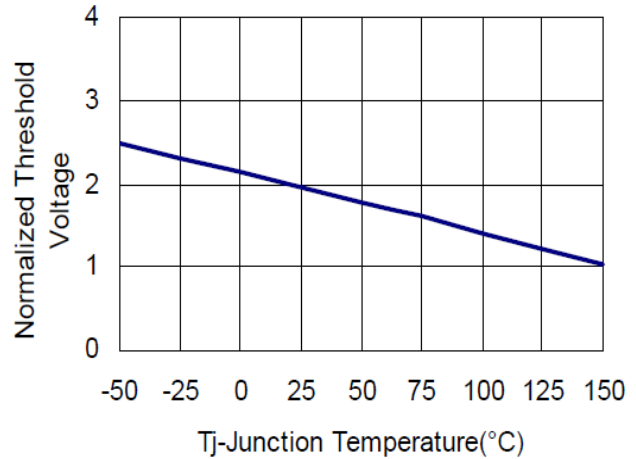

16. Gate Charge

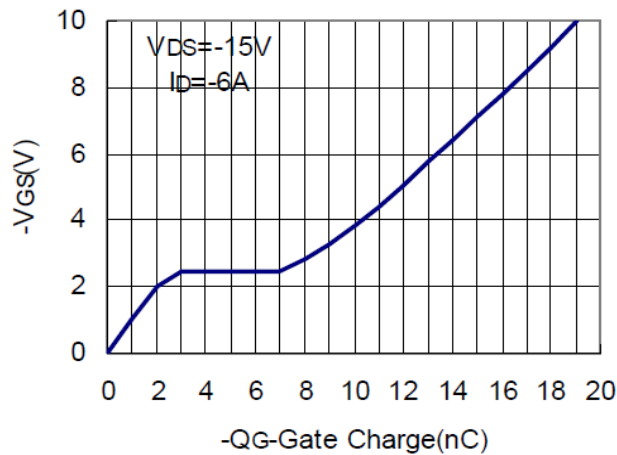

17. Drain Source On Resistance

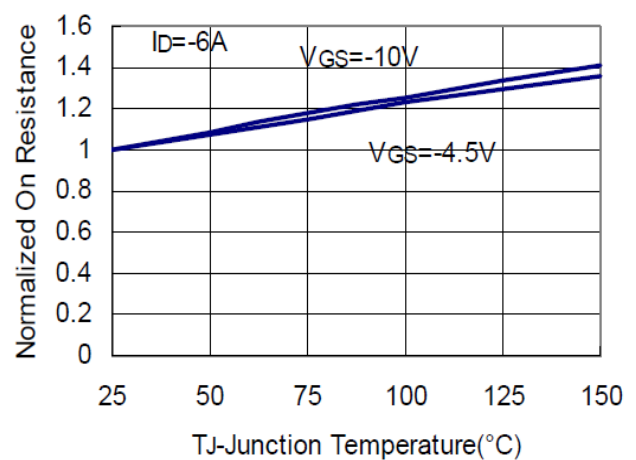



18. Source Drain Diode Forward

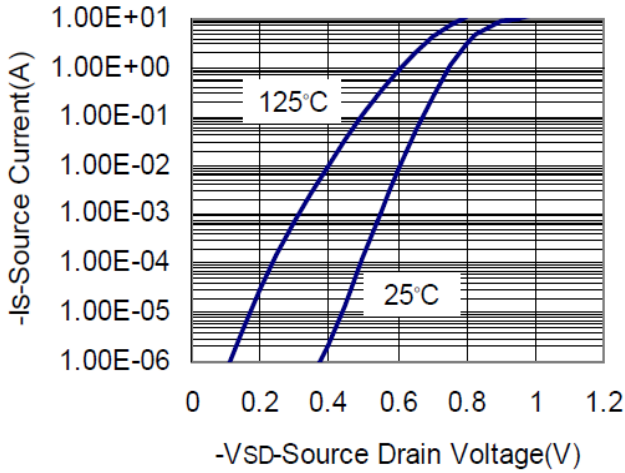

19. Capacitance

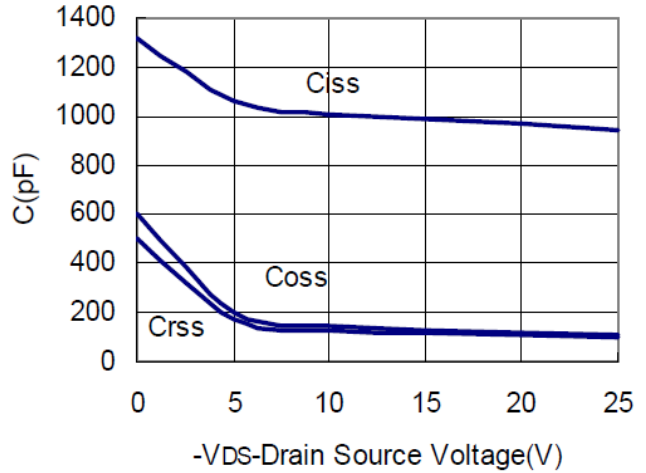

20. Power Dissipation

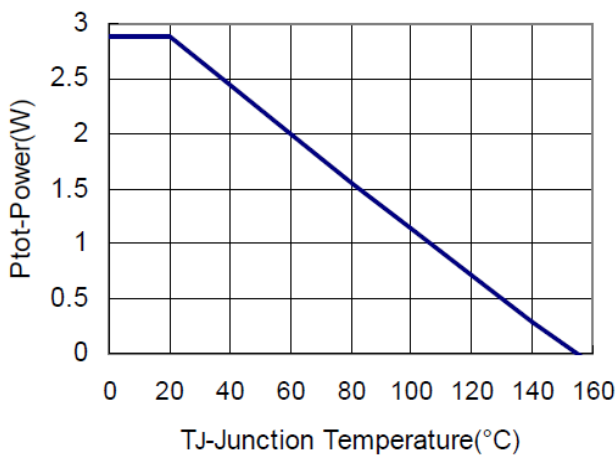

21. Drain Current

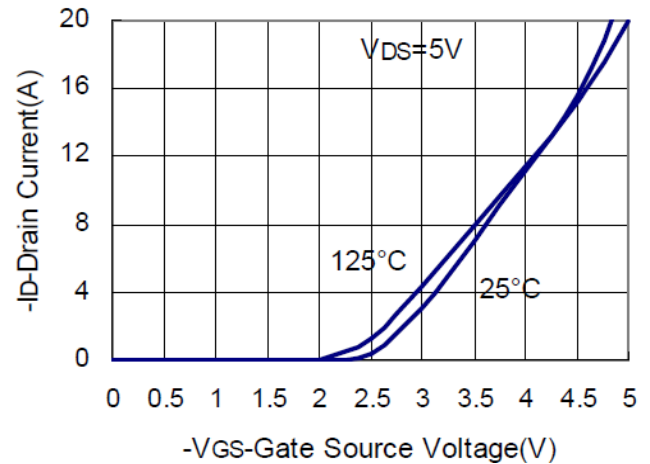

22. Thermal Transient Impedance

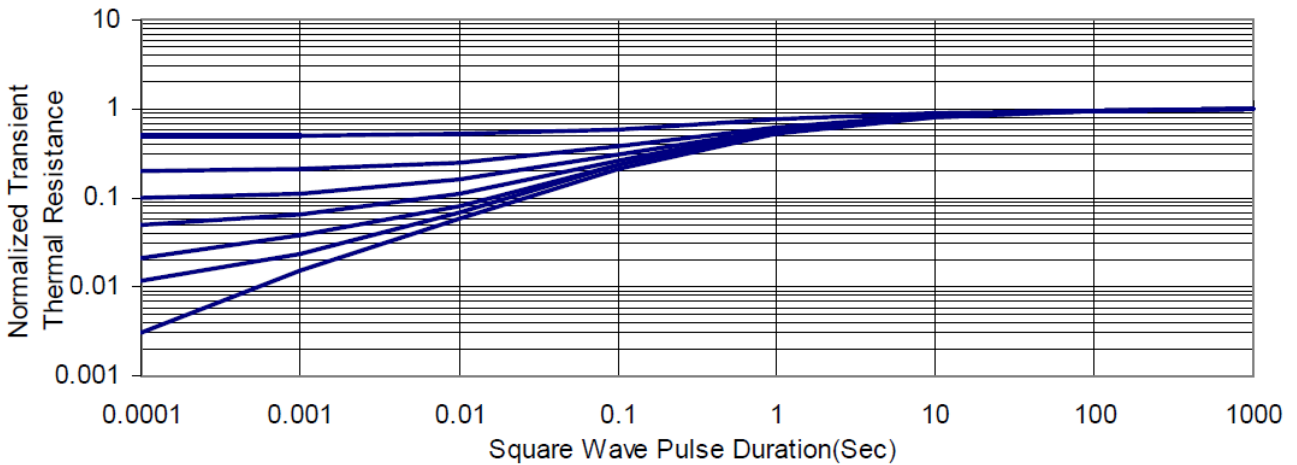



PACKAGE INFORMATION

Dimension in SOP-8 (Unit: mm)

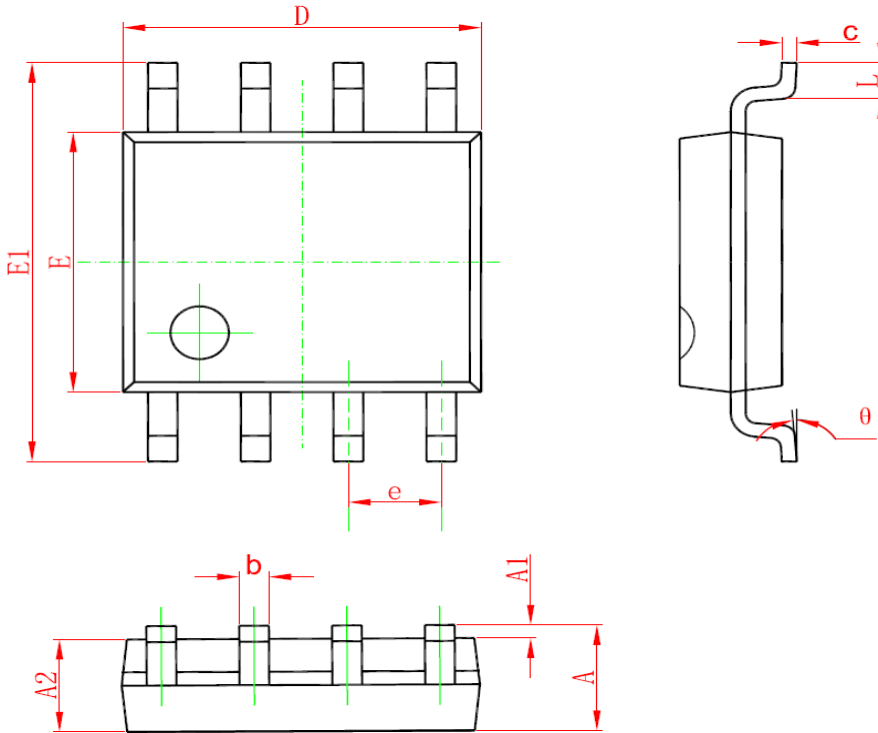

Symbol	Min	Max
A	1.350	1.750
A1	0.100	0.250
A2	1.350	1.550
b	0.330	0.510
c	0.170	0.250
D	4.700	5.100
E	3.800	4.000
E1	5.800	6.200
e	1.270(BSC)	
L	0.400	1.270
θ	0°	8°



IMPORTANT NOTICE

AiT Semiconductor Inc. (AiT) reserves the right to make changes to any its product, specifications, to discontinue any integrated circuit product or service without notice, and advises its customers to obtain the latest version of relevant information to verify, before placing orders, that the information being relied on is current.

AiT Semiconductor Inc.'s integrated circuit products are not designed, intended, authorized, or warranted to be suitable for use in life support applications, devices or systems or other critical applications. Use of AiT products in such applications is understood to be fully at the risk of the customer. As used herein may involve potential risks of death, personal injury, or severe property, or environmental damage. In order to minimize risks associated with the customer's applications, the customer should provide adequate design and operating safeguards.

AiT Semiconductor Inc. assumes to no liability to customer product design or application support. AiT warrants the performance of its products of the specifications applicable at the time of sale.