



## DESCRIPTION

The A7801 is a low noise, constant frequency (400kHz) switched capacitor voltage doubler. It produce a regulated output voltage from a 2.5V to 5.5V input with up to 250mA of output current. Low external parts count (one flying capacitor and two small bypass capacitors at  $V_{IN}$  and  $V_{OUT}$ ) make the A7801 ideally suited for small, battery-powered applications.

A new charge-pump architecture maintains constant switching frequency to zero load and reduces both output and input ripple. The A7801 have thermal shutdown capability and can survive a continuous short circuit from  $V_{OUT}$  to GND. Built-in soft-start circuitry prevents excessive inrush current during start-up.

High switching frequency enables the use of small ceramic capacitors. A low current shutdown feature disconnects the load from  $V_{IN}$  and reduces quiescent current to  $<1\mu A$ .

The A7801 is available in SOT-26 package.

## ORDERING INFORMATION

Package Type	Part Number	
SOT-26	E6	A7801E6R
		A7801E6VR
Note	V: Halogen free Package R: Tape & Reel	
AiT provides all RoHS products Suffix " V " means Halogen free Package		

## FEATURES

- Fixed 5V  $\pm$  4% Output
- $V_{IN}$  Range: 2.5V to 5.5V
- Output Current: Up to 250mA
- Constant Frequency Operation at All Loads
- Low Noise Constant Frequency (400kHz) Operation
- Automatic Soft-Start Reduces Inrush Current
- Shutdown Current  $<1\mu A$
- Short-Circuit Protection
- No Inductors
- Available in SOT-26 Package

## APPLICATION

- White LED Backlighting
- Li-Ion Battery Backup Supplies
- Local 3V to 5V Conversion
- Smart Card Readers
- PCMCIA Local 5V Supplies

## TYPICAL APPLICATION

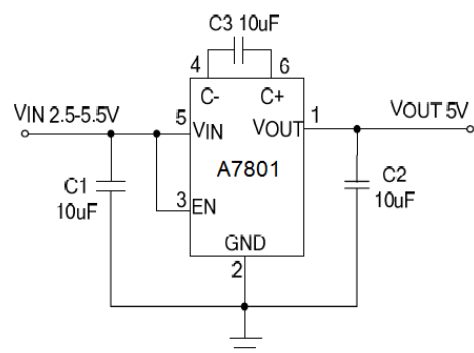
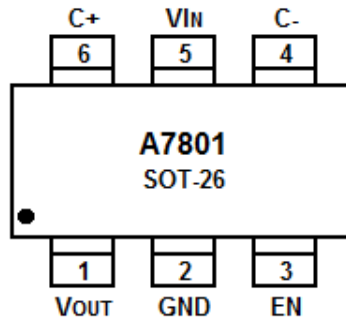

Figure 1. Basic Application Circuit with A7801



## PIN DESCRIPTION



Top View

Pin #	Symbol	Function
1	V <sub>OUT</sub>	Regulated Output Voltage. V <sub>OUT</sub> should be bypassed with a low ESR ceramic capacitor providing at least 2.2 $\mu$ F of capacitance as close to the pin as possible for best performance.
2	GND	Ground Pin.
3	EN	Active Low Shutdown Input. This pin must not be allowed to float.
4	C-	Flying Capacitor Negative Terminal.
5	V <sub>IN</sub>	Input Supply Voltage. V <sub>IN</sub> should be bypassed with a low ESR ceramic capacitor providing at least 2.2 $\mu$ F of capacitance as close to the pin as possible for best performance.
6	C+	Flying Capacitor Positive Terminal.



## ABSOLUTE MAXIMUM RATINGS

V <sub>IN</sub>	-0.3V~+6V
V <sub>OUT</sub>	-0.3V~5.5V
V <sub>OUT</sub> Short-circuit Duration	Indefinite
V <sub>EN</sub>	-0.3V~+6V
I <sub>OUT</sub> NOTE1	300mA
Operating Temperature Range NOTE2	-40°C~85°C
Lead Temperature (Soldering 10 sec.)	300°C
Storage Temperature Range	-65°C~125°C

Stress beyond above listed "Absolute Maximum Ratings" may lead permanent damage to the device. These are stress ratings only and operations of the device at these or any other conditions beyond those indicated in the operational sections of the specifications are not implied. Exposure to absolute maximum rating conditions for extended periods may affect device reliability.

NOTE 1: Based on long term current density limitations.

NOTE 2: The A7801 are guaranteed to meet performance specifications from 0°C to 70°C. Specifications over the -40°C to 85 operating temperature range are assured by design, characterization and correlation with statistical process controls.

## ELECTRICAL CHARACTERISTICS

EN= V<sub>IN</sub>, C<sub>IN</sub>=C<sub>OUT</sub>=10uF, T<sub>A</sub> = 25°C, Test Circuit of Figure 1, unless otherwise noted.

Parameter	Symbol	Conditions	Min.	Typ.	Max.	Unit
Input Voltage Range	V <sub>IN</sub>		2.5		5.5	V
Output Voltage Range	V <sub>OUT</sub>	2.7V < V <sub>IN</sub> < 5.5V, I <sub>OUT</sub> < 65mA	4.7	5.0	5.2	V
Shutdown Current		EN=0V, V <sub>OUT</sub> = 0V		0.3		μA
No Load Input Current		V <sub>IN</sub> = 2.7V, I <sub>OUT</sub> = 0mA		0.65		mA
Output Current Limit				250		mA
Output Ripple	V <sub>R</sub>	V <sub>IN</sub> = 2.7V, I <sub>OUT</sub> = 100mA		150		mVP-P
Efficiency		V <sub>IN</sub> = 2.7V, I <sub>OUT</sub> = 100mA		81		%
Open-Loop Output Resistance ROL= (2V <sub>IN</sub> -V <sub>OUT</sub> )/I <sub>OUT</sub>		V <sub>IN</sub> = 2.7V, I <sub>OUT</sub> = 100mA		4.0		Ω
Switching Frequency	f <sub>OSC</sub>			400		kHz



## TYPICAL PERFORMANCE CHARACTERISTICS

Test Figure 1 above unless otherwise specified

### 1. Output Voltage vs. Supply Voltage

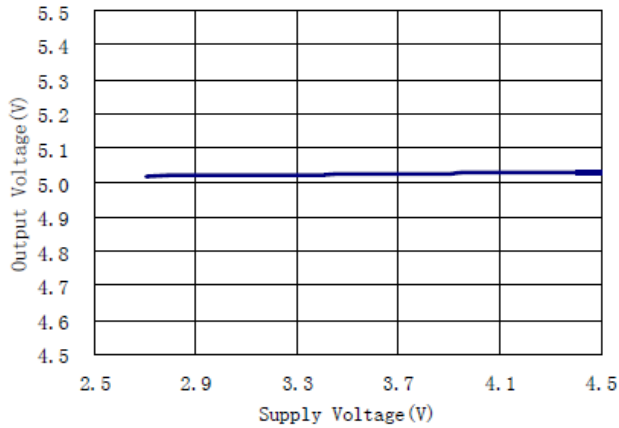

### 2. No Load Supply Current vs. Supply Voltage

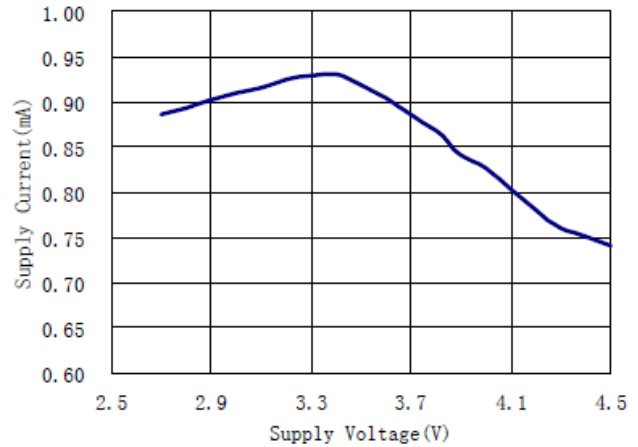

### 3. Oscillator Frequency vs. Supply Voltage

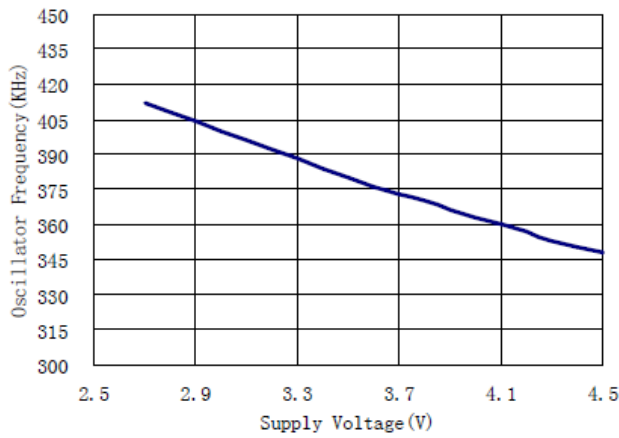

### 4. $\eta$ vs. $I_o$

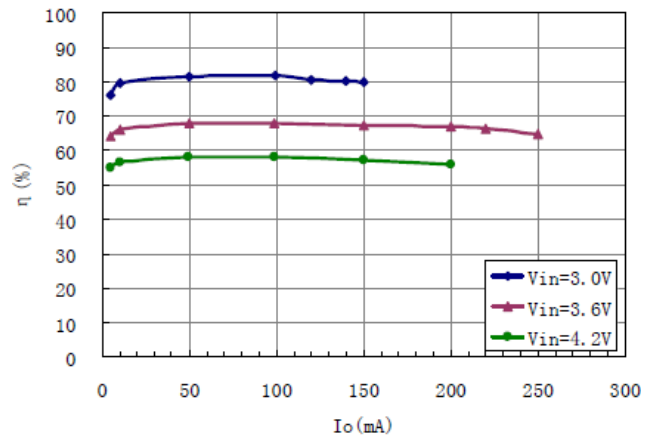



**BLOCK DIAGRAM**

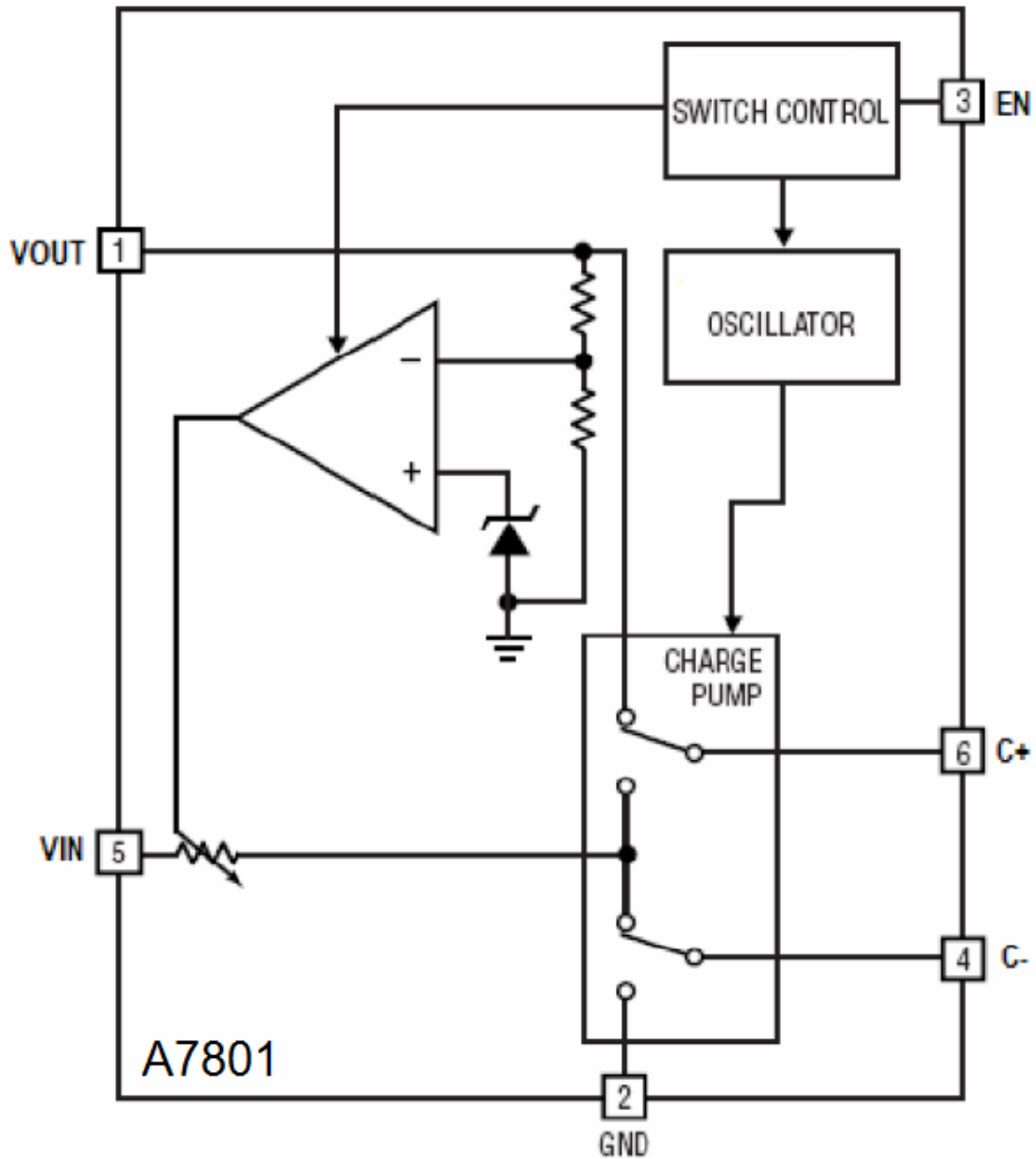



## DETAILED INFORMATION

### Operation

The A7801 use a switched capacitor charge pump to boost  $V_{IN}$  to a regulated output voltage. Regulation is achieved by sensing the output voltage through an internal resistor divider and modulating the charge pump output current based on the error signal. A 2-phase non overlapping clock activates the charge pump switches. The flying capacitor is charged from  $V_{IN}$  on the first phase of the clock. On the second phase of the clock it is stacked in series with  $V_{IN}$  and connected to  $V_{OUT}$ . This sequence of charging and discharging the flying capacitor continues at a free running frequency of 0.4MHz (typ). In shutdown mode all circuitry is turned off and the A7801 draw only leakage current from the  $V_{IN}$  supply. Furthermore,  $V_{OUT}$  is disconnected from  $V_{IN}$ . The EN pin is a CMOS input with a threshold voltage of approximately 0.8V. The A7801 is in shutdown when a logic low is applied to the EN pin. Since the EN pin is a high impedance CMOS input it should never be allowed to float. To ensure that its state is defined it must always be driven with a valid logic level.

### Short-Circuit Protection

The A7801 have built-in short-circuit current limiting. During short-circuit conditions, they will automatically limit their output current to approximately 300mA.

### Soft-Start

The A7801 have built-in soft-start circuitry to prevent excessive current flow at  $V_{IN}$  during start-up. The soft-start time is preprogrammed to approximately 1ms, so the start-up current will be primarily dependent upon the output capacitor.

### $V_{IN}$ , $V_{OUT}$ Capacitor Selection

The style and value of capacitors used with the A7801 determine several important parameters such as regulator control loop stability, output ripple, charge pump strength and minimum start-up time. To reduce noise and ripple, it is recommended that low ESR ( $< 0.1\Omega$ ) ceramic capacitors be used for both  $C_{IN}$  and  $C_{OUT}$ . These capacitors should be 2.2uF or greater. Tantalum and aluminum capacitors are not recommended because of their high ESR. The value of  $C_{OUT}$  directly controls the amount of output ripple for a given load current. Increasing the size of  $C_{OUT}$  will reduce the output ripple at the expense of higher minimum turn on time and higher start-up current. The peak-to-peak output ripple is approximately given by the expression:

$$V_{RIPPLE\_P} \cong \frac{I_{OUT}}{2F_{OSC} \cdot C_{OUT}}$$



Where  $f_{osc}$  is the A7801 oscillator frequency (typically 0.4MHz) and  $C_{OUT}$  is the output charge storage capacitor.

Both the style and value of the output capacitor can significantly affect the stability of the A7801. The A7801 use a linear control loop to adjust the strength of the charge pump to match the current required at the output. The error signal of this loop is stored directly on the output charge storage capacitor.

The charge storage capacitor also serves to form the dominant pole for the control loop. To prevent ringing or instability on the A7801 it is important for the output capacitor to maintain at least 2.2uF of capacitance over all conditions.

Likewise excessive ESR on the output capacitor will tend to degrade the loop stability of the A7801.

Ceramic capacitors typically have exceptional ESR performance and combined with a tight board layout should yield very good stability and load transient performance.

As the value of  $C_{OUT}$  controls the amount of output ripple, the value of  $C_{IN}$  controls the amount of ripple present at the input pin ( $V_{IN}$ ). The input current to the A7801 will be relatively constant while the charge pump is on either the input charging phase or the output charging phase but will drop to zero during the clock non overlap times. Since the non overlap time is small (~25ns), these missing "notches" will result in only a small perturbation on the input power supply line. Note that a higher ESR capacitor such as tantalum will have higher input noise due to the input current change times the ESR. Therefore ceramic capacitors are again recommended for their exceptional ESR performance.

### Flying Capacitor Selection

Warning: A polarized capacitor such as tantalum or aluminum should never be used for the flying capacitor since its voltage can reverse upon start-up of the A7801. Low ESR ceramic capacitors should always be used for the flying capacitor.

The flying capacitor controls the strength of the charge pump. In order to achieve the rated output current it is necessary to have at least 2.2uF of capacitance for the flying capacitor.

For very light load applications the flying capacitor may be reduced to save space or cost. The theoretical minimum output resistance of a voltage doubling charge pump is given by:

$$R_{OL(MIN)} \cong \frac{2V_{IN} - V_{OUT}}{I_{OUT}} \cong \frac{1}{F_{OSC} C_{FLY}}$$

Where  $f_{osc}$  is the switching frequency (0.4MHz typ) and  $C_{FLY}$  is the value of the flying capacitor. The charge pump will typically be weaker than the theoretical limit due to additional switch resistance, however for very



light load applications the above expression can be used as a guideline in determining a starting capacitor value.

### Power Efficiency

The power efficiency of the A7801 is similar to that of a linear regulator with an effective output voltage of twice the actual input voltage. This occurs because the input current for a voltage doubling charge pump is approximately twice the output current. In an ideal regulating voltage doubler the power efficiency would be given by:

$$\eta \equiv \frac{P_{OUT}}{P_{IN}} = \frac{V_{OUT} \bullet I_{OUT}}{V_{IN} \bullet 2I_{OUT}} = \frac{V_{OUT}}{2V_{IN}}$$

At moderate to high output power the switching losses and quiescent current of the A7801 are negligible and the expression above is valid. For example with  $V_{IN} = 3V$ ,  $I_{OUT} = 50mA$  and  $V_{OUT} = 5V$  the measured efficiency is 80% which is in close agreement with the theoretical 83.3% calculation.

### Layout Considerations

Due to its high switching frequency and the high transient currents produced by the A7801, careful board layout is necessary. A true ground plane and short connections to all capacitors will improve performance and ensure proper regulation under all conditions.





## PACKAGE INFORMATION

Dimension in SOT-26 (Unit: mm)

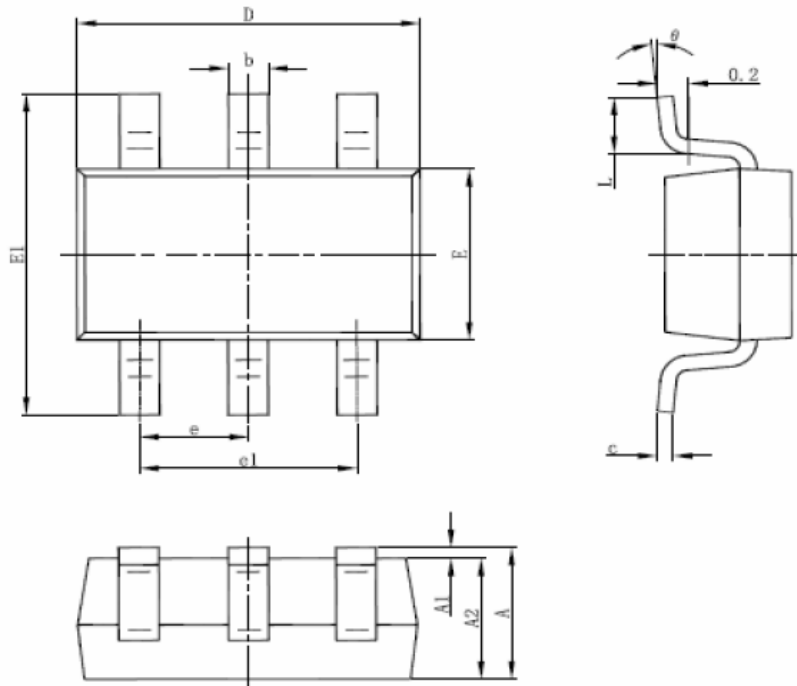

Symbol	Min	Max
A	1.050	1.250
A1	0.000	0.100
A2	1.050	1.150
b	0.300	0.500
c	0.100	0.200
D	2.820	3.020
E	1.500	1.700
E1	2.650	2.950
e	0.950(BSC)	
e1	1.800	2.000
L	0.300	0.600
$\theta$	0°	8°



## IMPORTANT NOTICE

AiT Semiconductor Inc. (AiT) reserves the right to make changes to any its product, specifications, to discontinue any integrated circuit product or service without notice, and advises its customers to obtain the latest version of relevant information to verify, before placing orders, that the information being relied on is current.

AiT Semiconductor Inc.'s integrated circuit products are not designed, intended, authorized, or warranted to be suitable for use in life support applications, devices or systems or other critical applications. Use of AiT products in such applications is understood to be fully at the risk of the customer. As used herein may involve potential risks of death, personal injury, or severe property, or environmental damage. In order to minimize risks associated with the customer's applications, the customer should provide adequate design and operating safeguards.

AiT Semiconductor Inc. assumes to no liability to customer product design or application support. AiT warrants the performance of its products of the specifications applicable at the time of sale.